

TIMEGUARD®

Pan & Tilt Bracket

Model: LEDCSTSSBRB – Black

Model: LEDCSTSSBRWH – White



Installation & Operating Instructions

1. General Information

These instructions cover the installation of the Pan & Tilt bracket for the LEDCST coastal grade floodlight range as specified below. These instructions should be read carefully in full before installation, and retained for further reference and maintenance.

2. Safety

- Be careful with the tools used during installation to prevent accidents or damage.
- If the product is installed without following the designated method, the product may be unstable and cause a safety issue.
- It is recommended that a qualified electrician is consulted or used for the installation of these products and install in accordance with the current IEE wiring and Building Regulations.

3. Technical Specifications

- For use with models;

LEDCST10B-WH

10W LED Coastal Grade Floodlights

LEDCST20B-WH

20W LED Coastal Grade Floodlights

LEDCST30B-WH

30W LED Coastal Grade Floodlights

LEDCST10PIRB-WH

10W LED Coastal Grade PIR Floodlight

LEDCST20PIRB-WH

20W LED Coastal Grade PIR Floodlight

LEDCST30PIRB-WH

30W LED Coastal Grade PIR Floodlight

- CE Compliant

4. Installation

- 4.1 Ensure that the mains supply to the circuit breaker is switched off and the circuit supply fuses are removed or the circuit breaker turned OFF.

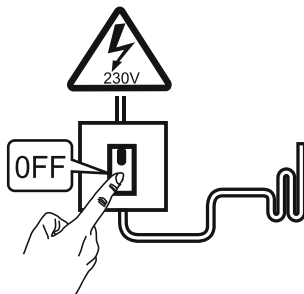

Image 1

2

- 4.2 Mark the position of the mounting holes on the wall using the bracket as a template.

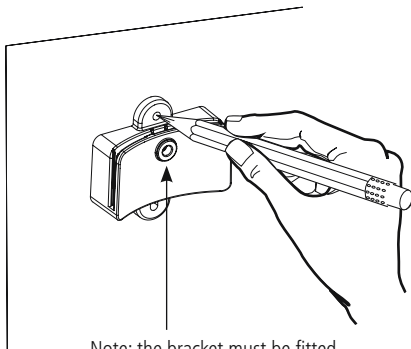

Image 2

Note: the bracket must be fitted this way up i.e. with the hand screw hole at the top

- 4.3 Drill the holes for the rawl plugs ensuring not to infringe with any gas/water pipes or electrical cables that may be hidden below the surface. Insert the rawl plugs.

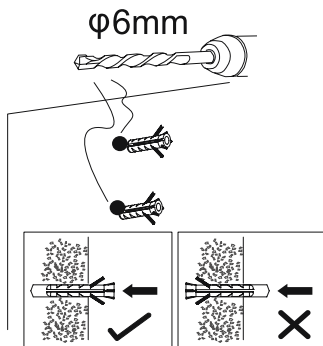

Image 3

3

- 4.4 Fix the bracket to the wall using the correct mounting screws for the wall plugs installed. Slot in the U- bracket. Make sure it goes to the bottom. Screw in the hand screw just enough to secure into place, but do not over tighten.

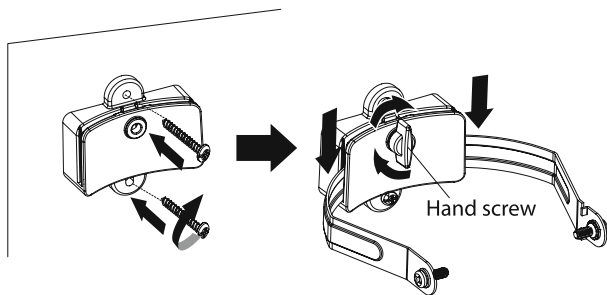

Image 4

- 4.5 Remove the fixing screws and washers from each side of the bracket, taking note of the order as you remove them.
- 4.6 Attach the floodlight to the bracket fitted to the wall using the fixing screws and washers previously removed. Screw in on both sides just enough to secure into place, but do not overtighten.

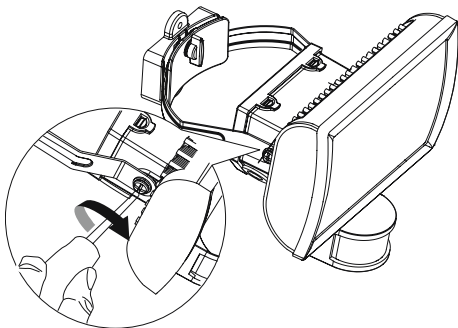

Image 5

4

- 4.7 Adjust the angle of the floodlight (left and right pan as shown in image 6, up and down tilt where the floodlight is attached to the bracket) so it lights the required area. Finally tighten the fixing screws and hand screw to secure the floodlight into position.

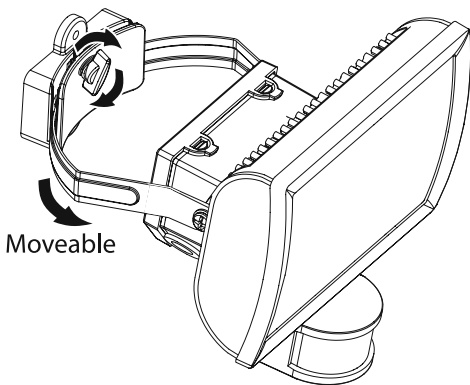

Image 6

3 Year Guarantee

In the unlikely event of this product becoming faulty due to defective material or manufacture within 3 years of the date of purchase, please return it to your supplier in the first year with proof of purchase and it will be replaced free of charge.

For years 2 and 3 or any difficulty in the first year, telephone the helpline on 020 8450 0515.

Note: A proof of purchase is required in all cases. For all eligible replacements (where agreed by Timeguard) the customer is responsible for all shipping/postage charges outside of the UK. All shipping costs are to be paid in advance before a replacement is sent.



If you experience problems, do not immediately return the unit to the store. Telephone the Timeguard Customer Helpline;

HELPLINE

020 8450 0515

or email helpline@timeguard.com

Qualified Customer Support Co-ordinators will be on-line to assist in resolving your query.



A **theben** Group Company

For a product brochure please contact:

Timeguard Limited.

Victory Park, 400 Edgware Road,
London NW2 6ND

Sales Office: 020 8452 1112
or email csc@timeguard.com

www.timeguard.com