

36W ENERGY SAVER PIR FLOODLIGHT

Cat No. EC036PIR - Black



Installation & Operating
Instructions



INSTALLATION & OPERATING
INSTRUCTIONS

1. GENERAL INFORMATION

The unit utilises passive infrared technology to detect heat radiation of moving human bodies.

Upon detection, the lamp will illuminate for a user-determined time period.

An integral daylight sensor ensures night-only operation.

The bulb supplied with the ECO36PIR is a class B (high efficiency) unit of 36W power consumption giving a similar but more diffuse light output to the lower efficiency 150W halogen units previously in use.

PARTS INCLUDED

- PIR flood light unit.
- Instruction manual. Please keep safe for future reference.
- Spiral 36W lamp.

TOOLS & PARTS NEEDED

- Electric/hand-held drill & bits.
- Terminal or Electricians screwdriver
- Medium slotted/philips screwdriver
- Wire cutters

This product is suitable for wall mounting. (Unsuitable for soffit mounting).

2. SELECTING THE LOCATION

The motion detector has a number of detection areas, at various vertical and horizontal angles as shown (see Figs. 1 & 2).

A moving human body needs to move between zones within one of these areas to activate the sensor. The best all-round coverage is achieved with the unit mounted at the optimum height of 2.5m. Forward looking range will be reduced by approx. 0.4m if the mounting height is 4m with sensor angled slightly downward.

Careful positioning of the sensor will be required to ensure optimum performance.

See Fig. 1 detailing detection range (the ranges shown depend on the face of the PIR lens being vertical to the ground).

The sensor is more sensitive to movement ACROSS its field of vision than to movement directly TOWARDS (see Fig. 2). Therefore position the unit so that the sensor looks ACROSS or to ONE SIDE of the likely approach path.

Avoid positioning the sensor where there are any sources of heat in the detection area (extractor fans, central heating flues, tumble dryer exhausts etc.).

Reflective surfaces (ie pools of water or white-painted walls) and overhanging branches may cause false activation under extreme conditions.

During extreme weather conditions the motion sensor may exhibit unusual behaviour. This does not indicate a fault with the sensor. Once normal weather conditions return, the sensor will resume normal operation.

The unit should be mounted with the following minimum clearances:-

Above and to each side 0.3m. In front 1.0m

3. INSTALLATION

Before proceeding further fit the lamp to the flood light. To do this remove the 4 screws retaining the front glass and frame using a suitable cross point or flat blade screwdriver referring to Fig. 3. Remove the frame and glass being sure to retain the screw sealing rings and the frame gasket.

Remove the spiral lamp from its box, ensure the lamp holders within the flood light are in the open position (see Fig. 4a). Insert each end of the lamp into the lamp holders and rotate the lamp through 90° so that the lamp holders are as shown in Fig. 4b.

After choosing a suitable location (see previous section) install the unit as follows:

***** IMPORTANT *****
Switch off the electricity at the consumer unit by removing the relevant fuse or switching off the relevant circuit breaker before proceeding with the installation.

Remove the wiring box cover by unscrewing the 4 retaining screws (Fig. 5) and remove the cover being careful to retain the 4 screw sealing rings and the cover gasket. The unit is suitable for connection to a 230 V ac 50Hz electricity supply. It is suggested that 3-core round flexible cable of 1mm² gauge is used. An isolating switch should be installed to switch the power to the unit ON & OFF. This allows the sensor to be easily switched off when not required or for maintenance purposes and to invoke manual override (see section 6).

Mark the position of the 2 fixing holes (see Fig. 6). Drill the holes. Insert the wall plugs into the holes if necessary and drive the 2 screws in until the back of the heads are approx. 3mm clear of the wall.
BEFORE PROCEEDING, slacken off the cable gland and pass the cable through it. Fix the mounting bracket to the wall by pushing the larger part of the keyhole over the screw head and then sliding the bracket downwards so that the screw sits at the top of the narrow section of the keyhole. Tighten the fixing screws.

FRONT GLASS REMOVAL

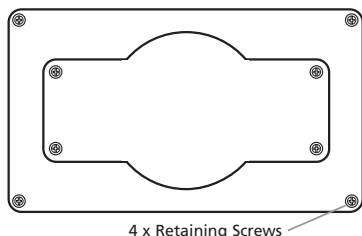

Fig. 3

LAMPHOLDER POSITION



Fig. 4a

Fig. 4b

WIRING BOX COVER

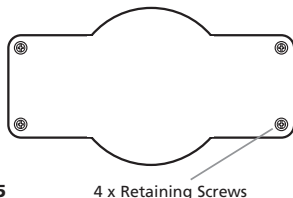

Fig. 5

MOUNTING BRACKET

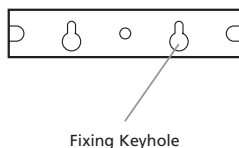

Fig. 6

CONNECTION

Rotate the flood light so that the front glass looks back towards the wall, giving good access to the connector block.

Take out the 2 screws holding the connector block in place and remove the connector block to ease wiring.

Connect the mains supply cable to the terminal block as follows (see Fig. 7 connection diagram):

NEUTRAL (Blue)	N
EARTH (Green/Yellow)	⊕
LIVE (Brown)	L

Ensure the connections are secure. Replace the connector block and replace and tighten the 2 fixing screws. Adjust any excess cable and tighten the cable gland. Refit the wiring box cover.

WIRING BOX CONNECTION DIAGRAM

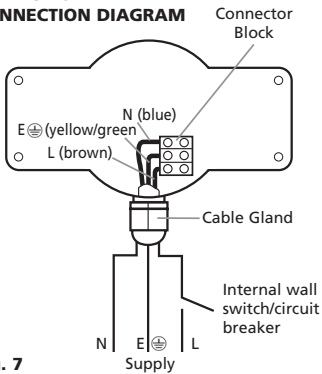

Fig. 7

CONTROLS

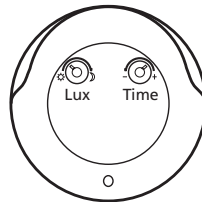

Fig. 8

4. WALK TESTING AND OPERATION

WALK TEST PROCEDURE

The sensor will rotate from left to right, and tilt forward or backward. Adjust the sensor to point in the required direction (see Figs. 1 & 2).

The unit can be set up in daylight or at night. The adjustment knobs are on the base of the detector (see Fig. 8). Lux should be set to the Sun ☀ setting (fully anti-clockwise) and Time is set to the minimum — (fully anti-clockwise).

Turn the power to the unit on. The lamp will illuminate for approximately 30 seconds. This indicates the unit is wired correctly.

The unit is now in Walk Test Mode.

We suggest that, since the 30 seconds minimum delay is rather long to be standing completely still, a minimal pattern of walks into the detection area (see Figs. 1 & 2) followed by a quick retreat out of the area waiting 30 seconds before a different walk is tried is a realistic method of proving the detection area.

If the area is smaller than expected try angling the sensor upward.

If the area is too great try angling the sensor downward and, if appropriate, to one side.

SETTING UP FOR AUTOMATIC OPERATION

The time Control determines how long the light stays on following activation and after all movement ceases. It is approximately linear so the mid point gives around 31/2 minutes delay from last detection.

The required time can now be set.

An approximate setting for the Lux (light) control to give operation after dusk only is between 2/3 and 3/4 of the way round from the Sun ☀ position toward the Moon 🌙 position. This setting can be fine tuned after observing the units performance at dusk.

INFRA-RED COVERAGE AREA

SIDE VIEW

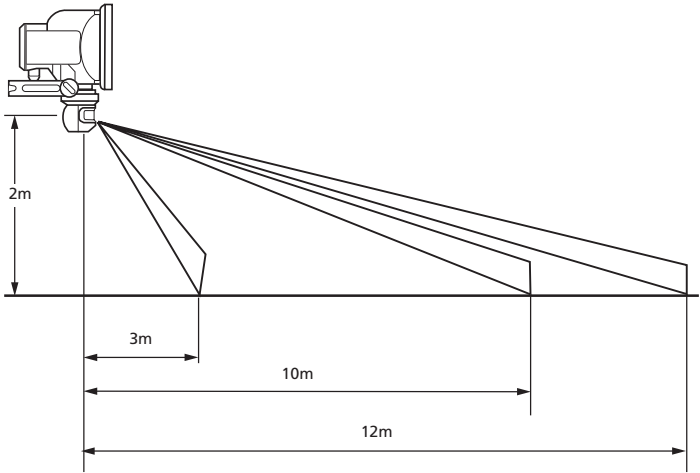

TOP VIEW

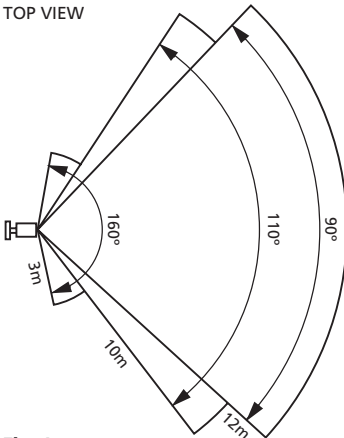

Fig. 1

AIMING DIRECTIONS

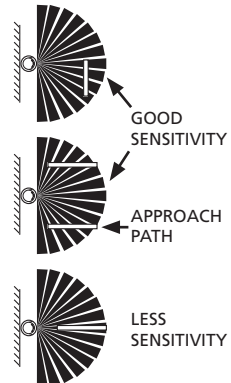

Fig. 2

MANUAL OVERRIDE MODE

The light can be switched on for longer time periods by use of the Manual Override Mode. This can be activated at night by using the internal wall switch or circuit breaker.

Switch the internal wall switch/circuit breaker twice (on/off once) within 1/2 to 2 seconds. The unit will now illuminate continuously until it is switched back into Auto Mode.

To get switch the unit back into Auto Mode, switch the internal wall switch/circuit breaker off for 10 or more seconds and then back on again. The unit will return to Auto Mode.

5. TECHNICAL SPECIFICATIONS

Detection Range	Up to 12 metres
Detection Angle	Up to 160°
Power Supply	230 V AC ~ 50Hz
Maximum Switchable Lamp Load	36W Low Energy Spiral bi-pin tube*
Time On Adjustment	30 seconds - 7 minutes approx.
Dusk Level Adjustment	Day & night or night only operation
Environmental Protection	IP44 (suitable for outdoor use)
EC Directives	Conforms to 73/23/EEC, 89/336/EEC

*** Should you experience difficulty in obtaining replacement lamps, these are available from Timeguard Limited, please ring the helpline number below.**

If you experience problems refer to Troubleshooting Guide.

If problems still persist, do not immediately return the unit to supplier. Telephone the Timeguard Customer Helpline

020 8450 0515

Qualified Customer Support Co-ordinators will be on-line to assist in resolving your query.

Ενεργεια
Energy 

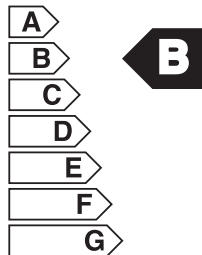

Using lamp supplied

6. TROUBLESHOOTING GUIDE

PROBLEM

SOLUTION

❑ Lamp stays ON all the time at night.

The unit may be suffering from false activation. Cover the sensor lens completely with a thick cloth. This will prevent the sensor from "seeing" anything. If the unit now switches off after the set time duration and does not re-activate, this indicates that the problem was caused by false activation. The problem may be solved by slightly adjusting the direction/angle of the sensor head.

If the unit persists in turning on with the cover over the lens, it is faulty.

❑ PIR keeps activating for no reason / at random.

Ensure the unit is not in manual override mode by switching the internal wall switch/circuit breaker off for at least 10 seconds and then back on again.

Ensure that there are no central heating flues, extractor fans in or close to the detection area.

Occasionally, wind may activate the sensor particularly if there are bushes in the detection area. Sometimes passages between buildings etc. can cause a "wind tunnel" effect.

Ensure the unit is not positioned so as to allow detection of cars/people using public thoroughfares adjacent to your property.

❑ PIR sensor will not operate at all.

Check that the power is switched ON at the circuit breaker/ internal wall switch.

Turn OFF the power to the unit and check the lamp. If the lamp has failed, replace. Ensure that the lamp is seated correctly in the lampholder.

Turn OFF the power to the unit and check the wiring connections as per the diagram (see fig. 7). Ensure no connections are loose.

❑ The PIR sensor will not operate at night.

The level of ambient light in the area may be too bright to allow operation at the current Lux setting. During the hours of darkness, adjust the Lux control slowly anti-clockwise until the lamp illuminates.

❑ Unit activates during the daytime

The level of ambient light in the area may be too dark for the current Lux setting. During daylight, adjust the Lux control slightly clockwise. When the lamp load extinguishes, enter the detection area. If the PIR still activates, the setting is still too high. Repeat the above procedure until the PIR does not activate when you enter the detection area.

❑ PIR coverage is poor/ sporadic

Unit may be poorly located. See previous section - 'Selecting The Location' and consider relocating the unit.

❑ Detection range varies from day to day

PIR sensors are influenced by climatic conditions. The colder the ambient temperature, the more effective the sensor will be. You may need to make seasonal adjustments to the sensor head position to ensure trouble-free operation all year round.

3 YEAR GUARANTEE



In the unlikely event of this product becoming faulty due to defective material or manufacture, within 3 years of the date of purchase, please return it to your supplier in the first year with proof of purchase and it will be replaced free of charge. For years 2 and 3 or any difficulty in the first year telephone our helpline on 020 8450 0515. This guarantee does not apply to the bulb.

For assistance with the product please contact:-

HELPLINE

020-8450-0515

or email helpline@timeguard.com



For a product brochure please contact:

Timeguard Ltd.

Victory Park, 400 Edgware Road,
London NW2 6ND Tel: 020-8452-1112
or email csc@timeguard.com

A **theben** Group company