

theben

310 781 01

RAMSES 786-1

OpenTherm

Ⓓ **Bedienungsanleitung**

Uhrenthermostat

ⒼⒷ **Operating Instructions**

Clock thermostat





Description



Overview



Settings by the end user



Settings to be made only by qualified electrician or heating engineer



A1 Selection of program type

Daily or weekly program



B1 Coding switch



A2 Weekly program



B2 Control types



A3 Daily program



B3 PI control

(not ambient temperature dependent)



A4 Set actual time

Summer / Winter time adjustment



B4 Weather-dependent control

(ambient temperature dependent)



A5 Switching pre-selection



B5 Setting of domestic water function



A6 Operating mode switch



B6 Temperature compensation for adjustment to location conditions



A7 Setting domestic water temperature



Safety information



A8 Starting domestic water heating immediately



B7 Electrical connections



A9 Operating status display



B8 Installation in living areas

Description

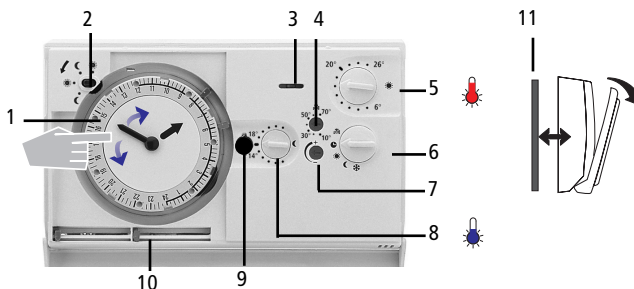

- 1 **RAM 786-1** with switchable day / weekly program (with tappets)
- 2 Manual switching and display normal ☀ or energy saving operation ☾ (night)
- 3 Display for operating state
- 4 Setting of domestic water temperature
- 5 Setting of daily temperature ☀
- 6 Operating mode switch in position:
 - 🕒 Programming clock for day or energy-saving mode
 - ☀ Day mode only
 - ☾ Energy-saving mode only
 - ❄ Frost protection mode only (fixed setting +6 °C)
 - 🏠 Domestic water heating only (summer operation)
- 7 Temperature compensation for adjustment to location conditions 🌑
- 8 Setting reduction temperature (energy-saving program) ☾
- 9 Seal for product security
- 10 Tappet holder
- 11 Vent slots in base



Overview

The Operating Manual is divided into two sections:

- A Operation and setting of the device by the end user**
- B Connection and settings to be made only by qualified electrician or heating engineer**

Designated use

The **RAM 786-1** thermostat is a continuous regulator for the time-dependent control of room and domestic water temperature. The thermostat uses the OpenTherm bus protocol.

The control unit may only be connected to heaters that bear the OpenTherm  symbol.

The unit combines high control comfort with easy operation.

Consequences of non-compliance

If the unit is **not** connected to an OpenTherm device or directly to an alternative supply source, the possibility of damage to both the heater and the **RAM 786-1** control unit cannot be ruled out.

A

Settings by the end user

A1

Selection of program type Daily or weekly program

Note: The control can be operated in either the daily or weekly program mode.

Effect of the daily program: The times set with the red and blue tappets for normal and reduced temperature are repeated daily.

Weekly program operation: The red and blue tappets can be used to enter the set times for normal and reduced temperature individually for each day of the week.



The unit is supplied with the factory-set daily program!

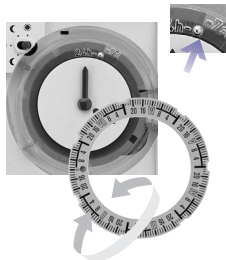

Changing over to the weekly program:

- Take off the graduated ring.
- Move the large hand until the groove in the blue and the groove in the green ring cover each other.
- Slide the drive pin into position 7 d.
- Turn the graduated ring over and set it up again.



Changing over to the daily program:

- Remove the graduated ring.
- Move the large hand until the groove in the green and the groove in the blue ring cover each other.
- Slide the drive pin into position 24 h.
- Refit the graduated ring so that the groove fits the metal pin in position 7 d (see figure).



Weekly program

Setting the program

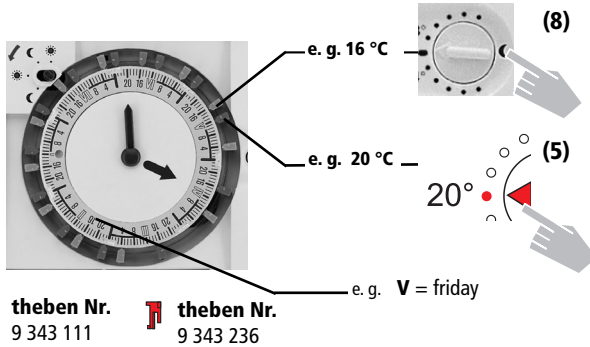

The shortest programmable time between heat and reduced is 2 hours.



The tappets can be inserted down to intervals of 30 mins.

Example for weekly program at normal temperature ☀ from:

Mon - Fri: 4⁰⁰ - 8⁰⁰ hrs and 16⁰⁰ - 20⁰⁰/ **Sat:** 8⁰⁰ - 0⁰⁰/ **Sun:** 8⁰⁰ - 20⁰⁰

Starts normal program ☀ and ends energy saving program ☾ .

Starts energy saving program ☾ and ends normal program ☀ .

Set the tappets at the following times from Monday (I) to Friday (V):

- Red tappet at 04:00 hrs and blue tappet at 08:00 hrs
- Red tappet at 16:00 hrs and blue tappet at 20:00 hrs

Saturday (VI): • Red tappet at 08:00 hrs and blue tappet at 00:00 hrs

Sunday (VII): • Red tappet at 08:00 hrs and blue tappet at 20:00 hrs



Please note! Push all tappets fully in!

A3

Daily program Setting program

Example: Setting the normal program ☀ daily from 06:00 to 08:00 hrs



Set the red tappet to 06:00 hrs.

Set the blue tappet to 08:00 hrs.

Please note: Push all tappets fully in!

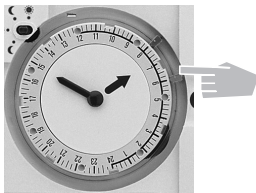

The shortest programmable time between heat and reduced is 20 mins.



The tappets can be inserted down to intervals of 5 mins.

A4

Setting current time / summer / winter adjustment



Turn **only the large hand** in a clockwise or counter-clockwise direction until the current time is displayed.



14°

Current time: e.g. 14:00 hrs 14:00



Please note: 14:00 hrs, not 02:00 hrs!

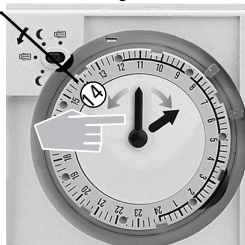

Switching pre-selection

- Manual switch (2) in position ☀ ; the setting of the rotary switch ☀ (5) determines the temperature.
- Manual switch (2) in position ☾ ; the setting of the rotary switch ☾ (8) determines the temperature.

Please note:

A 1 degree reduction in temperature is equivalent to approx. 6% energy saving.

Manual switch (2) for the switching pre-selection



Manual switch (2) for the switching pre-selection

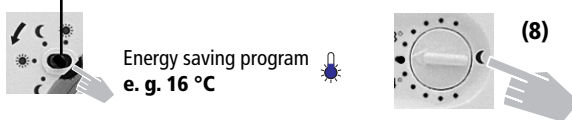

Operating mode switch

Domestic water heating is dependent upon the coding set on the rear of the unit.

The coding on your unit is as follows:

A
 B

Coding A

The operating mode switch (6) has the following functions:

Summer mode

The heater is switched to frost protection at 6 °C. The domestic water is heated up in dependence of the programmed switching times. In daily operation (see fig. 1), the setting on rotary switch (4) controls the temperature of the domestic water. In reduced operation, the domestic water is only heated up if it drops below a temperature of +10 °C.

Automatic mode

The programmed times on the clock determine the period of the day ☀ / reduced temperature ☾ in the room. In daily operation (see fig. 1), the setting of the rotary switch (4) controls the temperature of the domestic water. In reduced operation, the domestic water is only heated up if it drops below a temperature of +10 °C.

Permanent setting - day temperature

The setting of the rotary switch ☀ (5) determines the normal temperature in the room. The domestic water is permanently maintained at the temperature set by the rotary switch (4).

Permanent setting - energy saving mode

The setting of the rotary switch ☾ (8) determines the reduced temperature in the room. Domestic water is then only heated up if it drops below a temperature of +10 °C.

Permanent setting - frost protection mode

If the room temperature drops below +6 °C, the controller demands more heat. If the temperature of the domestic water drops below +10 °C, the heater switches on automatically.



Abb. 1



Operating mode switch

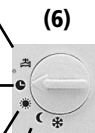

Coding B:

The operating mode switch **(6)** has the following functions:



Summer mode

The heater is switched to frost protection at 6 °C.
The domestic water is heated further.
The setting of the rotary switch  **(4)** controls the temperature of the domestic water.



Automatic mode

The programmed times on the clock determine the period of the day  / reduced temperature  .
The domestic water is permanently maintained at the temperature set by the rotary switch  **(4)**.

Permanent setting - day temperature

The setting of the rotary switch  **(5)** controls the day temperature in the room. The domestic water is permanently maintained at the temperature set by the rotary switch  **(4)**.

Permanent setting - energy saving mode

The setting of the rotary switch  **(8)** determines the reduced temperature of the room. The domestic water is permanently maintained at the temperature set by the rotary switch  **(4)**.

Permanent setting - frost protection mode

If the room temperature drops below +6 °C, the controller demands more heat.
Domestic water is then only heated up if it drops below a temperature of +10 °C.

(6)



A7

Setting domestic water temperature

The domestic water temperature is heated to a maximum of the value set on the heater.

Setting range: 10 ... 70 °C

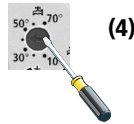

Drop the front cover down.



Set the required domestic water temperature by the rotary switch **(4)**.

A8

Starting domestic water heating immediately

e.g. for instantaneous additional warm water



Turn the operating mode switch **(6)** to position  and then back to its original position.

The domestic water heater is activated immediately.

A9

Operating status display

The LED illuminates green.

Indicating: Correct operation

The LED illuminates red.

Indicating: Malfunction on the heater

Call the Hotline.

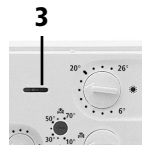

The LED does not illuminate (Bus communication interrupted).

Indicating: Malfunction

Call the Hotline.



B

Settings to be made only by qualified electrician or heating engineer

B1

Coding switch

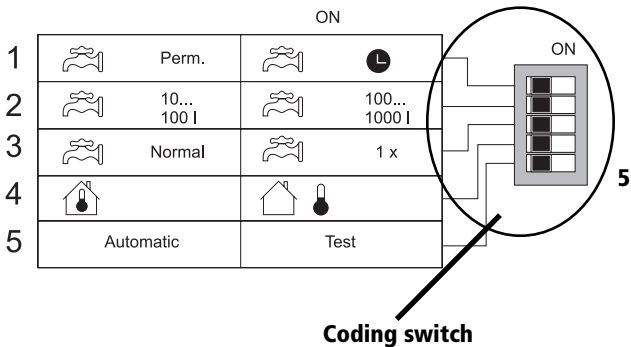

A coding switch is located at the back of the unit.
To activate the desired function for domestic water preparation, push the relevant coding switch into the position shown.

Note:

Coding switch **5** is a manufacturer's test switch.
It must be set to **OFF** (see fig.).

The functions of coding switches 1, 2, 3, 4 are described in the following Section.

Control types

Thermostat **RAM 786-1** can either be used as a weather-dependent regulator (dependent on ambient temperature), as a PI regulator (room-temperature dependent) or as a combination of the two types.

The regulator can be programmed to the desired type using the coding switch at the back of the unit.

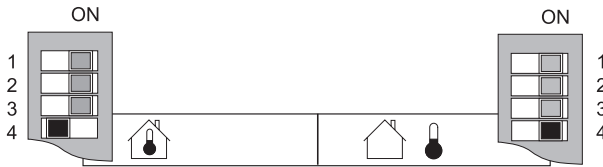

If coding switch **4** is set to **OFF**, the PI regulator is activated, if it is set to **ON**, Thermostat **RAM 786-1** becomes weather-dependent.

Further explanations on setting the control parameters for each regulator type appear in **Sections B3 and B4**.

B3

PI control (not ambient temperature dependent)

Thermostat **RAM 786-1** operates as a PI regulator.



To activate PI control, set the following coding at the back of the unit.

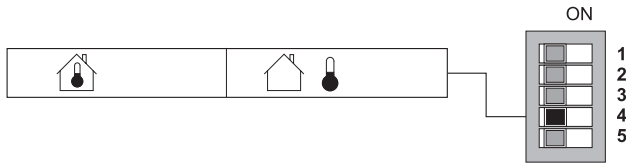

The control characteristics can be set via a rotary switch (see fig.) at the back of the unit.



Room influence setting:

- | | | |
|-----------------------------------|----------------------|------------|
| - Passive heating system | (underfloor heating) | 1-3 |
| - Standard heating system | (radiator heating) | 4-6 |
| - Over-dimensioned heating system | (radiator heating) | 7-9 |

Weather-dependent control

Effect:

In this operating mode, Thermostat **RAM 786-1** works as a weather-dependent boiler control. The control characteristics are determined by the following parameters:

- Base point
- Steepness
- Room influence (PI)

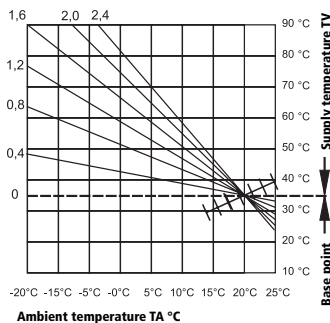

To activate weather-dependent parameters, set the following coding at the back of the unit:

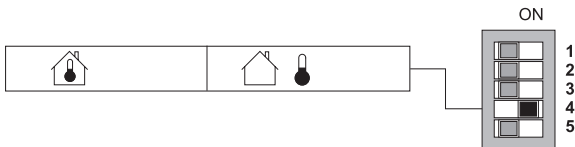

Set the parameters for your heating system.
Establish what type of heating system you have.

Clarification: 90/70 =	90 °C supply temperature, 70 °C return temperature	
Radiator heating	maximum temperature	setting: 90 / 70
Radiator heating	medium temperature	setting: 70 / 50
Radiator heating	low temperature	setting: 50 / 35
Underfloor heating	low temperature	setting: 40 / 30

➡ See the table below for steepness / base point values:

		Heating curve Steepness $\Delta T_V / \Delta T_A$									
Heating system	Base point	0,5	0,7	0,9	1,1	1,3	1,5	1,7	1,9	2,1	2,3
40/ 30	20°C		X								
	25°C	X									
50/ 35	20°C				X						
	25°C			X							
70/ 50	30°C						X				
	35°C					X					
90/ 70	30°C										X
	35°C									X	

➡ Set the temperature of the base point and the determined steepness value at the back of the unit.

Steepness

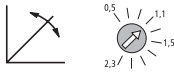

Base point

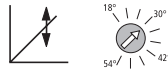

➡ Set the room influence:



Offset supply temperature = ΔT_V

Room influence factor = PI

Setpoint value of room temperature = $T_{R \text{ setpoint}}$

Actual value of room temperature = $T_{R \text{ actual}}$

$$\Delta T_V = PI (T_{R \text{ setpoint}} - T_{R \text{ actual}})$$

Example: $T_{R \text{ setpoint}} = 20 \text{ °C}$ $T_{R \text{ actual}} = 18 \text{ °C}$ $PI = 3$

$$\Delta T_V = 3 \times (20 \text{ °C} - 18 \text{ °C}) = 6 \text{ K}$$

Consequence: The supply temperature is increased by 6 K.



We recommend the following settings:

Underfloor heating

1-4

Radiator heating with:

- weak compensation

1-3

- medium compensation

4-6







- strong compensation

7-9

At a setting with value 0, no room compensation is carried out.
The regulator carries out only a temperature-dependent control.

What should I do if the desired room temperature is not achieved?



Ambient temperature during the day	too cold	Room temperature	too warm
+5 °C to +15 °C	 set 0.2 less and  5 K higher	 set 0.2 higher  5 K lower	
-20 °C to +5 °C	 set 0.2 higher		 set 0.2 lower

Setting the domestic water functions

Effect:

The domestic water temperature can be controlled by thermostat **RAM 786-1**. Select the desired domestic water heating from the following functions.

Heating time of domestic water

Function with Coding A:

The domestic water is heated up to the programmed comfort phase, only if the manual switch (2) is set to the following position:

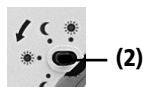

 Set the following coding:

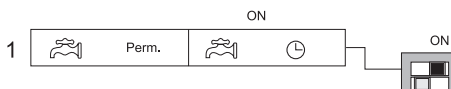

Funktion with Coding B:

The domestic water is permanently controlled at the temperature set by the rotary switch (4).

 Set the following coding:

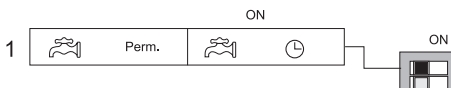

Make a note in box in Section **A6** whether you have set **Coding A** or **B**!

Setting the volume of the domestic water tank

1. Domestic water tank in use has a capacity greater than 100 l.

Set the following coding:



2. Domestic water tank in use has a capacity smaller than 100 l.

Set the following coding:

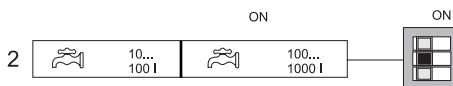

Domestic water energy saving mode

Function: Given normal water consumption and a large water tank, constant re-heating is not necessary. The domestic water is heated only **once** at the start of the programmed comfort phase (time program on clock).

Precondition:

This function is useful if the domestic water tank in use has a capacity of more than 100 l and the domestic water is to be heated only at the programmed comfort times.

To do this, set the following coding:

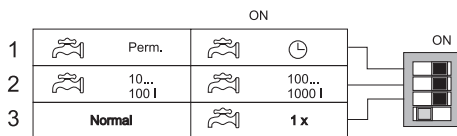

Heat up domestic water again as required.

Briefly turn the operating mode switch (6) to summer mode

and then back again.

Temperature adjustment to match location conditions

- Temperature adjustment to match location conditions.
- The clock thermostat is factory-set. If, as a result of the mounting location, e.g. a cold concrete wall, the thermostat has to be re-set, adjust the measured temperature deviation at the rotary switch (7) .

Possible adjustment range: +/-3 K

Please note:

When adjusting to suit location conditions, no disturbance variables such as draughts, strong sunshine etc. must prevail.

Example: The controlled temperature is too low in relation to the set temperature.



Turn the rotary switch (7) in the + direction (repeat adjustment if necessary).

After you have adjusted the temperature using the rotary switch, the room temperature has to be reset. After approx. 30 minutes, the temperature deviation can be re-established (repeat the process if necessary).

Power reserve in the event of mains failure

Thermostat **RAM 786-1** has a power reserve. This means that if the power should fail, the clock continues to run and the program sequence is retained.

Please note:

The unit takes a few minutes to start operating after the operating voltage is connected. The full power reserve (150 h) of the unit is reached after approx. 3 days.

B7

Electrical connection



The connection and the installation of electrical products may be effected only by a qualified electrician.

If clock thermostats are used in a lay-out with other products, attention must be given to ensure that the whole system does not cause radio interference.

National directives and relevant safety regulations must be observed. Interference with and changes to the product will result in the loss of the guarantee.



Please note:

- The control unit may only be connected to OpenTherm devices!
- Observe the  symbol.
- Never connect the device directly to the operating voltage.
=> It may be defect.
- Do not arrange the bus line parallel to a high-voltage power cable.

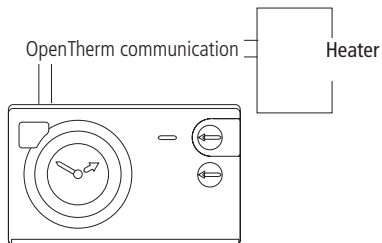

- Polarity does not need to be observed when connecting to the OpenTherm interface!

Installation in living area

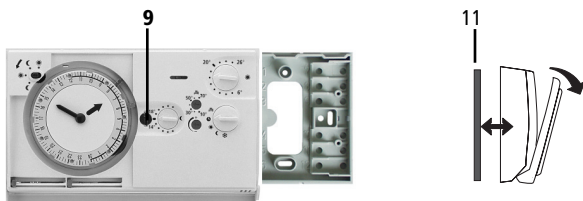



Ensure that when installing and dismantling the clock thermostat that the voltage in the connecting lead is switched off.

Mounting:

Do not mount the device on an even conductive base.



1. Lower the front cover.
2. With a screwdriver turn the seal **9** to position 
3. Lift the grey plinth from the control section without tilting.
4. Pull the connecting wires through the plinth.
5. Fix the plinth to the wall approx. 1.5 m above the floor, if possible on an internal wall, against which air can circulate without hindrance.
6. Connect the plinth in accordance with the applicable circuit diagram.
7. Press the connecting leads flat into the plinth.
8. Fit the clock thermostat to the wired plinth.
9. Turn the seal **9** into position with a screwdriver. 

Note: Keep the ventilation apertures **11** in the plinth free, no paint wallpaper or other such material.

Technical data

Operating voltage:	OpenTherm
Power reserve:	R 3d (72h)
Possible control type:	Weather-dependent or PI-controlled
Permitted ambient temperature:	0 °C ... +40 °C
Protection class:	II EN 60730-1 for designated installation
Protection rating:	IP 20 EN 60529 <u>I</u>

Setting range on control:

Comfort / reduced temperature:	+6 °C ... + 26 °C
Domestic water temperature:	+10 °C ... +70 °C
Frost protection temperature:	6 °C room temperature domestic water temperature permanently set to 10 °C

Adjustment to match location conditions:	between +/- 3 K
---	-----------------

Setting range on clock:

Shortest switching interval in daily program:	20 minutes
Tappets can be inserted at intervals of:	5 minutes

Weekly program:

Shortest switching interval:	2 hours
Tappets can be inserted at intervals of:	30 minutes

- (D)** **Theben AG**
Postfach 56
D-72394 Haigerloch
Telefon (0 74 74) 692-0
Telefax: (0 74 74) 692-150
Kundendienst:
Telefon (0 74 74) 692-369
Telefax (0 74 74) 692-207
www.theben.de
- (A)** SIBLIK ELEKTRIK GES.M.B.H & CO.KG,
Murbangasse 6, 1108 Wien,
Tel. 01/68006-0, Fax. 6800659
- (B)** TEMPOLEC International s.a.
Route de Biesme 49, B 6530 Thuin,
Tél. 071.59.00.39 (10 lignes)
Fax. 071.59.01.61
- (CH)** Theben (Schweiz) AG
Riedstrasse 6,
CH-8953 Dietikon,
Tel. 00 41 (0) 43/321 13 70
Fax. 00 41 (0) 43/321 13 75
- (DK)** BENNIKE + WANDER A/S,
Hændværkerbyen 57, 2670 Greve
Tel. 02/43908000, Fax. 43690090
- (E)** GUIJARRO HERMANOS S.L.,
Poligono Industrial
„Virgen de Butarque“, Isaac Peral 6,
28914 Leganes (Madrid)
Tel. 01 / 6870022, Fax. 6876616
- (F)** Theben S.A.R.L,
Zone Industrielle des Vignes,
32 – 38 Rue Bernard,
93012 Bobigny cédex,
Tél. 01/49159700, Fax. 48445761
- (GB)** TIMEGUARD LTD,
Victory Park, 400 Edgware Road
London NW2 6ND
Tel. 0181/4508944;
Fax. 0181/4525143
- (I)** Theben S.R.L., Via Ciro Menotti 11,
20129 Milano
Tel. 02/7386141/2/3/4,
Fax. 7386144
- (N)** GYLLING TEKNIKK A/S,
Rudsletta 71-75; P. O. Box 103;
1309 Rud, Tel. 067/151400;
Fax. 067/151401
E-Mail: gylling@gylling.no
- (NL)** ITHO B.V., P.O. Box 21,
3100 AA Schiedam
Tel. 010/4278500
Fax. 010/4278882
- (P)** DUARTE NEVES, L.D.A
BOX: Apartado 52064
1721-501 Lisboa
Tel. 351 21 754 1200
Fax. 351 21 754 1208 / 9
- (S)** GYCOM SVENSKA AB,
Box 1203, 18312 Täby,
Tel. 08-56201100, Fax. 08-792065
- (FIN)** SÄHKÖPALVELU THEBEN OY,
Vattuniemenkatu 17
PL 114, 00210 Helsinki
Tel. (09) 670 670
Fax. (09) 670 410