

MX Series Dimmer Actuator DMG 2, Upgrade Module DME 2 and Booster DMB 2

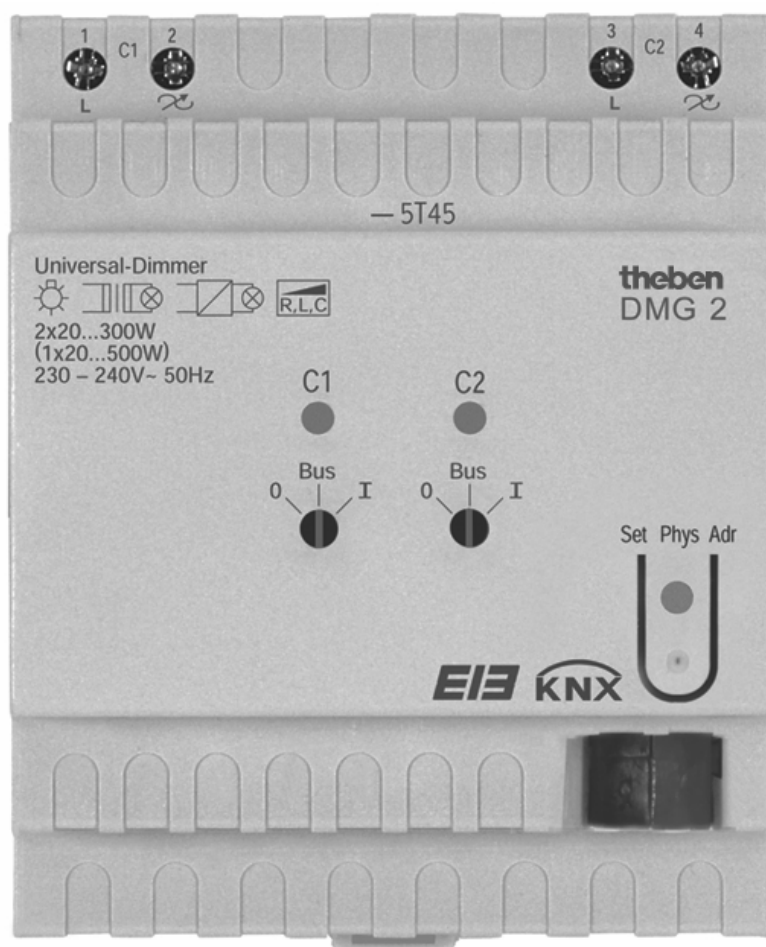

DMG 2	490 0 220
DME 2	490 0 221
DMB 2	490 0 222

Contents

1	FUNCTIONAL CHARACTERISTICS	3
1.1	GENERAL	4
1.2	OPERATION	4
1.3	FEATURES OF THE DIMMER ACTUATORS	4
2	TECHNICAL DATA	5
2.1	TECHNICAL DATA FOR DMG 2, DME 2 AND DMB 2	5
2.2	DIMMABLE LOADS.....	6
2.3	AUTOMATIC LOAD DETECTION	7
2.4	IMPORTANT INFORMATION	7
2.5	POWER DEMAND (W/VA) AND EXAMPLES OF POTENTIAL MODULE COMBINATIONS	8
3	THE APPLICATION PROGRAM “MIX SERIES V1.1 SWITCHING AND DIMMING“	9
3.1	SELECTION IN THE PRODUCT DATABASE.....	9
3.2	PARAMETER PAGES	10
3.3	COMMUNICATION OBJECTS.....	11
3.3.1	<i>Object characteristics</i>	12
3.3.2	<i>Object description</i>	13
3.4	PARAMETERS	18
3.4.1	<i>General</i>	18
3.4.2	<i>DMG 2 channel 1 S1, DMG 2 channel 2 S1, EM 1 DME 2 channel 1 S1, EM 2 DME 2 channel 1 S1 etc.</i>	19
3.4.3	<i>DMG 2 channel 1 S2, DMG 2 channel 2 S2, EM 1 DME 2 channel 1 S2, EM 2 DME 2 channel 2 S2 etc.</i>	21
4	APPENDIX	24
4.1	APPLICATIONS FOR THE "SOFT SWITCHING" FUNCTION	24
4.1.1	<i>General</i>	24
4.1.2	<i>Simulation of a daily routine</i>	24
4.1.3	<i>Soft ON for staircase lighting</i>	25
4.1.4	<i>Entrance lighting</i>	26
4.1.5	<i>Re-triggering and premature switch-off</i>	27
4.2	4-BIT TELEGRAMS (BRIGHTER/DARKER)	30
4.2.1	<i>4-bit EIS 2 telegram format for relative dimming:</i>	30
4.2.2	<i>Parameter: "Switching on/off with a 4-bit telegram"</i>	31
4.3	CONVERSION OF PERCENTAGES TO HEXADECIMAL AND DECIMAL VALUES.....	31
4.4	APPLICATION OF THE FORCED OPERATION FUNCTION	32
4.5	SAVING LIGHT SCENES IN A PUSH BUTTON	33
4.5.1	<i>Assignment of group addresses and setting for the object flags</i>	33
4.5.2	<i>Functional description</i>	33
4.6	DIMMER ACTUATOR PRIORITY SEQUENCE	34
4.7	FUNCTION DIAGRAM FOR STANDARD APPLICATIONS	35
4.8	GENERAL FUNCTION DIAGRAM.....	36

1 Functional characteristics

The **MX** Series is a range of devices comprising basic modules (e.g. DMG 2, RMG 4 S or RMG 4 C-Load) and upgrade modules (e.g. DME 2, DMB 2, RME 4 S or RME 4 C-Load). Up to 2 upgrade modules of your choice can be connected in series to any of the basic modules in the range.

Table 1

Designation	Description	Main features
DMG 2	2-channel dimmer, basic module	2 x 300 W or 1 x 500 W
DME 2	2-channel dimmer, upgrade module	
DMB 2	2-channel dimmer booster for DMG 2 / DME 2	Power upgrade by 2 x 300 W or 1 x 500 W
... other devices in the MX Series*		
RMG 4 S	4-channel switching actuator, basic module	16 A/channel for standard load types
RME 4 S	4-channel switching actuator, upgrade module	
RMG 4 C-Load	4-channel switching actuator, basic module	16 A/channel for load types with high switch-on peaks
RME 4 C-Load	4-channel switching actuator, upgrade module	

* When using a device from the RMG 4 S/C series, please refer to the handbook which is available on our homepage: <http://www.theben.de>

1.1 General

The DMG 2 Universal Dimmer is a series device. Using its outputs, it can dim or switch a group of electrical consumers such as lights with high-voltage halogen lamps or low-voltage halogen lamps with series-connected conventional or electronic transformers.

1.2 Operation

Each channel of the dimmer actuators has an LED which indicates its status and a manual switch with the settings ON/OFF/BUS. In order for the manual switch and the LED to work, the mains supply needs to be provided via the load. The bus voltage does not need to be present.

Turning the manual switch to "0" dims the load to 0% irrespective of all other parameters, and the status LED for the channel is switched off.

Turning the manual switch to "1" dims the load to 100% irrespective of all other parameters, and the status LED for the channel lights up red.

Turning the manual switch to the "Bus" setting allows you to control the dimmer via the bus. The status LED for the channel comes on at a dimmer value of 1% and is switched off at 0%.

In the event of overtemperature or a short circuit in the load the device dims down to 0%. In this case the status LED will flash.

1.3 Features of the dimmer actuators

- Manual switch for each channel
- Status LED for each channel
- High dimmer output, upgradeable with boosters to a maximum of 1000 W
- Upgradeable modular concept for a variety of applications
- Upgradeable to 6 channels per bus user
- Different modules can be combined to meet the exact requirements of the user and to offer the best possible value for money
- Possible integration of the channels into a maximum of 8 scenes
- Adjustable response to bus failure and restoration of the bus/mains power

2 Technical data

2.1 Technical data for DMG 2, DME 2 and DMB 2

	<i>Unit</i>	<i>DMG 2</i>	<i>DME 2</i>	<i>DMB 2</i>	<i>Comment</i>
Mains: 230V 50 Hz	W / VA	< 0.5		< 1.5	Per channel with open circuit
EIB power supply	mA	max. 10			
Minimum load	W / VA	20 *			Per channel
Channels per module	-	2			
Maximal symmetrical load	W / VA	2 x 300	2 x 300	Upgrade by 2 x 300	All channels used individually
Maximal asymmetrical load	W / VA	1 x 500	1 x 500	Upgrade by 500	Only one channel per module used
Example of asymmetrical load	W / VA	1 x 400 and 1 x 100	1 x 400 and 1 x 100	Upgrade by 1 x 400 and 1 x 100	Total output per module max. 500
Line length, dimmer - load	m	max. 100	Do not connect any other consumers to lines between load and dimmer.		
Fusing	Automatic cut-out - Characteristic B 16 A				
Terminal diameters	Solid: 0.5 mm ² (dia. 0.8) to 4 mm ² Strand with wire end sleeve: 0.5 mm ² to 2.5 mm ² Cross head screwdriver PZ 1				
Permitted ambient temp. Protection class Protection rating Equipment standard	-5 °C ... +45 °C (-5T45) II provided it is correctly installed IP 20 in accordance with EN 60529 EN 60669, EN 50090				
Housing	45 x 71 x 60 mm (4 TE)				

* refer to the next section below.

2.2 Dimmable loads

Table 2

Load type	Dimmable		Comment
	YES	NO	
Halogen lights and incandescent lamps for 230V~	X		-
Low-voltage halogen lights with electronic transformer	X		*
Low-voltage halogen lights with laminated core transformer	X		* With transformers of the type “dimmable” and at the minimum load
Low-voltage halogen lights with toroidal mains transformer		X	-
Mixed operation of low-voltage halogen lights with electronic transformer and 230V~ incandescent lamps	X		*
Compact fans (< 50W)	X		Only available on request and with the load type “inductive” pre-selected in the ETS database.
Metal halide lamps		X	-
Energy saving lamps		X	-
Fluorescent lamps		X	-
Lamps with own dimmer		X	-
Lamps with other electronic ballasts		X	-

* **Electronic and conventional transformers must always be operated at least at the minimum load specified by the manufacturer. Otherwise the dimmer or the transformer can be destroyed and the service life of the lamps can be reduced.**
Should no specifications be known, always connect at least 80% of the nominal load for the transformer.

2.3 Automatic load detection

Automatic load detection is performed in order to find the right dimmer strategy (phase control or reverse phase control) to apply.

In terms of dimming, a distinction is made between capacitive loads and resistive loads on the one hand and inductive loads on the other.

Table 3

Capacitive / resistive loads	Incandescent lamps, high-voltage halogen lamps, electronic transformers
Inductive loads	Conventional (wound) transformers

Automatic load detection is preset as a standard setting. Every time the mains voltage is switched on the device checks the load type and adjusts the settings accordingly. This means that if there is a switch connected in series with the dimmer, there will be a time delay every time the switch is switched on.

A database with setting options for load detection is available on request.

2.4 Important information

1. The voltage supply (at the fuse box) must be switched off without fail when replacing lamps.
2. The EIB voltage must be switched off when **plugging together or separating modules**.
3. Do not connect dimmers **in series or in parallel**.
ONLY the booster module is connected in parallel.
4. The dimmer **must not be bridged**.
5. Dimmable, electrically isolated lighting (e.g. in the bathroom):
Use 12V halogen lamps. Transformers for 12V halogen lamps are normally sufficiently well electrically isolated for this purpose.
6. Do not connect the dimmer to an **isolating transformer** or an **adjustable transformer**.
7. Ripple control pulses from electric power plants may cause temporary flickering of the lighting.

2.5 Power demand (W/VA) and examples of potential module combinations

Table 4

Power demand	Possible combination
2 x 300 W	DMG 2
1 x 350 W and 1 x 150 W	DMG 2
1 x 450 W and 1 x 50 W	DMG 2
1 x 500 W	DMG 2 (one channel used on the module, the other channel remains unconnected)
2 x 500 W	DMG 2 + DME 2 (1 channel each per module)
2 x 600 W	DMG 2 + DMB 2 (the two DMG 2 channels are upgraded with one DMB 2 channel each)
4 x 300 W	DMG 2 + DME 2
6 x 300 W	DMG 2 + DME 2 + DME 2
6 x 600 W	DMG 2 + DME 2 + DME 2 + 3 DMB 2 (both of the DMG 2 and DME 2 channels are each upgraded with one DMB 2 channel)
1 x 1000	DMG 2 + DMB 2 (one DMB 2 channel is upgraded with one DMB 2 channel)
3 x 1000 W	DMG 2 + DME 2 + DME 2 + 3 DMB 2 (one channel per device is used)

3 The application program “MiX Series V1.1 switching and dimming“

3.1 Selection in the product database

Manufacturer	Theben AG
Product family	Dimmer
Product type	DMG 2 with dimming and switching
Program name	MiX Series V1.1 switching and dimming

Download the application from: <http://www.theben.de>

Table 5

Number of communication objects	64
Number of group addresses	110
Number of associations	111

3.2 Parameter pages

Each channel has 2 parameter pages, and all channels have an identical layout.

Table 6

Function	Description
General	Selection of the connected upgrade modules and the general parameter for the cyclic sending of feedback
DMG 2 channel 1 S1	1st channel of the basic module: general dimming parameters
DMG 2 channel 1 S2	1st channel of the basic module: soft switching, forced operation etc.
DMG 2 channel 2 S1	2nd channel of the basic module: general dimming parameters
DMG 2 channel 2 S2	2nd channel of the basic module: soft switching, forced operation etc.
EM 1 DME 2 channel 1 S1	1st channel of upgrade module 1: general dimming parameters
EM 1 DME 2 channel 1 S2	1st channel of upgrade module 1: soft switching, forced operation etc.
EM 1 DME 2 channel 2 S1	2nd channel of upgrade module 1: general dimming parameters
EM 1 DME 2 channel 2 S2	2nd channel of upgrade module 1: soft switching, forced operation etc.
EM 2 DME 2 channel 1 S1	1st channel of upgrade module 2: general dimming parameters
EM 2 DME 2 channel 2 S2	1st channel of upgrade module 2: soft switching, forced operation etc.
EM 2 DME 2 channel 3 S1	2nd channel of upgrade module 2: general dimming parameters
EM 2 DME 2 channel 4 S2	2nd channel of upgrade module 2: soft switching, forced operation etc.

3.3 Communication objects

With the MiX Series, a maximum of 20 objects are available for each module. Object numbers 0...19 are reserved exclusively for the basic module, nos. 20...39 for the first upgrade module and nos. 40...59 for the second upgrade module. In addition there are the 3 central objects and the scene object, i.e. object nos. 60...63.

Objects 0 ... 19 (basic module) and the central objects are described in the table below. The object structure and its sequence are identical for the upgrade modules (EM 1 / EM 2) and the basic module (GM). The central objects apply to the entire system, i.e. basic module + upgrades.

3.3.1 Object characteristics

Table 7

	Object	Function	Object name	Type	Behaviour
Basic module	0	Switching ON/OFF	GM DMG 2 channel 1	1 bit	Receive
	1	Brighter/darker	GM DMG 2 channel 1	4 bits	Receive
	2	Dimming value	GM DMG 2 channel 1	1 byte	Receive
	3	Soft switch	GM DMG 2 channel 1	1 bit	Receive
	4	Forced operation ON/OFF Dimming value for forced operation	GM DMG 2 channel 1	1 bit 1 byte	Receive
	5	Feedback in %	GM DMG 2 channel 1	1 byte	Send
	6	Feedback ON/OFF	GM DMG 2 channel 1	1 bit	Send
	7	General error telegram	GM DMG 2 channel 1	1 bit	Send
	8	Load failure telegram Excess temperature telegram Short circuit telegram Load type telegram (RC/L) Bus/manual operation telegram	GM DMG 2 channel 1	1 bit	Send
	9	Status telegram (bit set)	GM DMG 2 channel 1	1 byte	Send
	10	Switching ON/OFF	GM DMG 2 channel 2	1 bit	Receive
	11	Brighter/darker	GM DMG 2 channel 2	4 bit	Receive
	12	Dimming value	GM DMG 2 channel 2	1 byte	Receive
	13	Soft switch	GM DMG 2 channel 2	1 bit	Receive
	14	Forced operation ON/OFF Dimming value for forced operation	GM DMG 2 channel 2	1 bit 1 byte	Receive
	15	Feedback in %	GM DMG 2 channel 2	1 byte	Send
	16	Feedback ON/OFF	GM DMG 2 channel 2	1 bit	Send
	17	General error telegram	GM DMG 2 channel 2	1 bit	Send
	18	Bus/manual operation telegram	GM DMG 2 channel 2	1 bit	Send
19	Status telegram (bit set)	GM DMG 2 channel 2	1 byte	Send	
Central	60	Switching ON/OFF	Central permanent ON	1 bit	Receive
	61	Switching ON/OFF	Central permanent OFF	1 bit	Receive
	62	Switching ON/OFF	Central switching	1 bit	Receive
	63	Call/save scene	Scene	1 byte	Receive

3.3.2 Object description

- **Objects 0, 10, 20, 30, 40, 50 "Switching ON/OFF"**

If there is a "1" on this object then the device dims up to 100%, if there is a 0 it dims down to 0%.

- **Objects 1, 11, 21, 31, 41, 51 "Brighter/darker"**

This object is actuated with 4-bit telegrams (EIS 2 relative dimming). This function can be used to dim the light up or down in increments (with 1...64 increments). In the standard application, telegrams are sent with 64 increments.

IMPORTANT: The response to the 4-bit telegrams depends on the parameter "Switching ON/OFF with 4-bit telegram".

See Appendix: [4-bit telegrams \(brighter/darker\)](#)

- **Objects 2, 12, 22, 32, 42, 52 "Dimming value"**

This object can be used to select the desired dimmer setting directly. Format: 1 byte percentage value EIS 2 dimming, value.

0 = 0%

255 = 100%

- **Objects 3, 13, 23, 33, 43, 53 "Soft switching"**

A "1" on this object starts a soft switching cycle, i.e.:

The brightness is gradually increased, starting from the minimum brightness. The dimming value remains constant for the programmed time and is then gradually reduced after this time has elapsed. Once the programmed minimum brightness has been reached the dimming value is reset to 0%. The cycle can be extended or prematurely terminated via telegrams.

This sequence can also be controlled with a **timer** if the parameter "*Time between soft ON and soft OFF*" is set to "*Until soft OFF telegram*".

The dimming cycle is then started with a "1" and finished with a "0".

See Appendix: [Applications for the "Soft switching" function](#)

- **Objects 4, 14, 24, 34, 44, 54 "Forced operation = 1" / "Forced operation = 0" / "Forced operation through dimming value"**

The function of the forced operation object can be parameterized as a 1-bit or 1-byte object.

Table 8

Parameterization	Forced operation		Behaviour in the event of forced operation	
	Trigger with	End with	Start	End
As 1-bit object	1 or 0 (parameterizable)	0 or 1 (parameterizable)	Parameterizable in the application program	
As 1-byte object	1 ... 255	0	The triggering telegram also acts simultaneously as a forced operation dimming value.	The last dimming value before forced operation is restored.

- **Objects 5, 15, 25, 35, 45, 55 "Feedback in %"**

Sends the new dimming value after a change as soon as a dimming procedure is completed, i.e. once the new setpoint value has been reached.

Format: 1 byte, 0 ... 255 i.e. 0 ... 100%

IMPORTANT:

This object must not be put onto the same group address as object 2.

- **Objects 6, 16, 26, 36, 46, 56 "Feedback ON/OFF"**

Sends the current dimming status:

1 = current dimming value is between 1% and 100%

0 = current dimming value is 0%

- **Objects 7, 17, 27, 37, 47, 57 "General error telegram"**

Used as a malfunction signal:

0 = no error

1 = an error has been detected

This telegram can be shown on a display for example.

For detailed error analysis refer to Object 9.

- **Objects 8, 18, 28, 38, 48, 58 "Load failure telegram", "Excess temperature telegram", "Short circuit telegram", "Load type telegram (R, C/L)", "Bus/manual operation telegram"**

The function of this object depends on the “Diagnosis and feedback” parameter. This enables more specific error telegrams.

Table 9

“Diagnosis and feedback” parameter	Function of object 8	Meaning
Feedback objects, status, general error	-	-
Load failure, feedback objects, status, general error	Load failure telegram	1= open circuit, failure of light source ¹ , automatic circuit-breaker tripped or no load connected.
Excess temp., feedback objects, status, general error	Excess temperature telegram ²	1= the dimmer is overloaded: <ul style="list-style-type: none"> • connected power is too high, • ambient temperature is too high, • incorrect installation position, i.e. device cannot dissipate the heat, • booster defective.
Short circuit, feedback objects, status, general error	Short circuit telegram	1= check connected lines and load
R,C/L load, feedback objects, status, general error	Load type telegram (R, C/L)	1= Reverse phase control: With a resistive or capacitive loads (R/C), e.g. electronic transformers or incandescent lamps. 0= phase control: With inductive loads, e.g. conventional transformers.
Bus/manual, feedback objects, status, general error	Bus/manual operation telegram	Indicates whether the switch on the dimmer housing is set to bus operation or not. 1 = manual operation (manual 0 or manual 1 position) 0 = bus (bus position)

¹ Failed light sources can only be detected if the current supply for 230V is effectively interrupted (halogen spot lamps or normal incandescent bulbs). If light sources are connected in parallel or there is a load failure on the 12V secondary side of a transformer then the system does not detect a load failure.

² This telegram should not be used to determine the maximum dimmable power in an application.

- **Objects 9, 19, 29, 39, 49, 59 "Bit set status telegram"**

Diagnosis object for status and error display.

Status information is encoded in a byte according to the following bit pattern.

Bit 7	Bit 6	Bit 5	Bit 4	Bit 3	Bit 2	Bit 1	Bit 0
n.a.	n.a.	x	x	x	x	x	x

x = value 1 or 0

n.a. = not assigned

Table 10

	Bit	Name	Meaning
Error	0	Load failure	1= open circuit, automatic circuit-breaker tripped or no load connected.
	1	Excess temperature	1= the dimmer is overloaded: <ul style="list-style-type: none"> • connected power is too high, • ambient temperature is too high, • incorrect installation position, i.e. device cannot dissipate the heat, • booster defective.
	2	Short circuit	1= check connected lines and load
Status	3	Type of load	1= reverse phase control (R, C load connected), electronic transformers or incandescent bulb test 0= phase control (L load connected), conventional transformers
	4	Manual/bus operation	1= manual switch on the device set to manual operation "0" or "1" 0= manual switch set to bus operation
	5	Dimming value	1= dimming value >0% 0= dimming value = OFF

- **Object 60 "Central permanent ON"**

This object is a central object. It can be configured to be effective on all channels.

If this object is set to "1" then all of the channels "participating" in this object are dimmed to 100%. If this object is set to "0" then it has no effect on the channels.

- **Object 61 "Central permanent OFF"**

This object is a central object. It can be configured to be effective on all channels.

If this object is set to "1" then all of the channels "participating" in this object are dimmed to 0%. If this object is set to "0" then it has no effect on the channels.

- **Object 62 "Central switching"**

This object is a central object. It can be configured to be effective on all channels. If a "1" or "0" is sent to this object then this is the same as if a "1" or "0" is sent to the switching objects of the channels (Object 0, Object 10, Object 20 ...). The same functionality could also be achieved by connecting all switching objects to the same group as that of this object.

Accordingly, using this object saves time during the assignment of the group addresses and also saves on the number of assignments.

- **Object 63 "Scene"**

This object can be used to save and subsequently call "Scenes".

The save process stores the current status of the dimming channel, regardless of how the status was brought about (e.g. via dimming values, switching commands, central objects or the manual switches).

The status saved in this way is restored when the saved status is called.

Each channel can participate in a maximum of 8 scenes.

The following telegrams need to be sent in order to call or save scenes:

Table 11

Function	Hexadecimal value	Decimal value	Function
Save scene 1	\$80	128	Each channel saves its current dimming value in the scene memory with the sent scene number, provided the channel is intended to participate in this scene. This scene memory remains alive even after bus failure or mains failure.
Save scene 2	\$81	129	
Save scene 3	\$82	130	
Save scene 4	\$83	131	
Save scene 5	\$84	132	
Save scene 6	\$85	133	
Save scene 7	\$86	134	
Save scene 8	\$87	135	
Call scene 1	\$00	0	Each channel adopts the dimming value stored in the scene memory under the sent scene memory, provided the channel is intended to take part in this scene.
Call scene 2	\$01	1	
Call scene 3	\$02	2	
Call scene 4	\$03	3	
Call scene 5	\$04	4	
Call scene 6	\$05	5	
Call scene 7	\$06	6	
Call scene 8	\$07	7	

3.4 Parameters

3.4.1 General

Table 12

Designation	Values	Meaning
Type of basic module	GM is a DMG 2	With this application only a DMG 2 can be used as the basic module.
Number of upgrade modules	No upgrade 1 upgrade module 2 upgrade modules	DMG 2 DMG 2 + 1 upgrade to the MiX Series DMG 2 + 2 upgrades to the MiX Series
Type of 1st upgrade module EM1	EM 1 is a DME 2 EM 1 is an RME 4 S or RME 4 C-Load	Upgrade basic module with 2 dimmer channels Basic module + switching actuator module
Type of 2nd upgrade module EM2	EM 2 is a DME 2 EM 2 is an RME 4 S or RME 4 C-Load	One additional upgrade module is used (see row above)
Time for cyclic sending of the feedback objects (if used)	2 minutes, 3 minutes 5 minutes, 10 minutes 15 minutes , 20 minutes 30 minutes, 45 minutes 60 minutes	At what time interval are the cyclic feedback telegrams to be sent?

Continued

Designation	Values	Meaning
Participation in central objects	<ul style="list-style-type: none"> - Yes: in all central objects - No: in no central object - only in central permanent ON - only in central permanent OFF - only in central switching - only in central switching and permanent ON - only in central switching and permanent OFF - only in central permanent ON and permanent OFF 	Defines which central objects the channel responds to.
Participation in scenes	<p>Yes: in the scenes 1 - 8</p> <ul style="list-style-type: none"> Yes: in the scenes 1 - 4 Yes: in the scenes 5 - 8 Yes: in the scenes 3 - 6 Yes: in the scenes 1 - 2 Yes: in the scenes 3 - 4 Yes: in the scenes 5 - 6 Yes: in the scenes 7 - 8 Yes: in the scenes 1,2,5,6 Yes: in the scenes 1,2,7,8 Yes: in the scenes 1 - 6 Yes: in the scenes 3 - 8 	Which scenes should the relevant channel be used in?
Behaviour after bus failure	<p>No change</p> <p>Minimum brightness</p> <p>100 %</p> <p>Off</p> <p>10 %, 20 %, 30 %</p> <p>40 %, 50 %, 60 %</p> <p>70 %, 80 %, 90 %</p>	<p>How should the dimmer respond if the bus voltage fails and controls via the bus are therefore no longer available?</p> <p>Here again the parameterized minimum brightness needs to be taken into account.</p>
Behaviour after restoration of the bus/mains power	<p>Same as before bus failure</p> <p>Minimum brightness</p> <p>100 %</p> <p>Off</p> <p>10 %, 20 %, 30 %</p> <p>40 %, 50 %, 60 %</p> <p>70 %, 80 %, 90 %</p>	<p>How should the dimmer respond when normal operation is resumed (bus and mains supplies present)?</p> <p>Here again the parameterized minimum brightness needs to be taken into account.</p>
Load selection (R, C or L)	<p>Automatic load detection (standard)</p> <p>R, C load (incandescent bulbs, electronic power units)</p> <p>L load (wound transformers)</p>	<p>The dimmer detects what type of load is connected and automatically selects the appropriate dimming strategy (phase control or reverse phase control).</p> <p>This setting cannot be changed.</p> <p>A database with manual load selection can be supplied on request.</p>

3.4.3 DMG 2 channel 1 S2, DMG 2 channel 2 S2, EM 1 DME 2 channel 1 S2, EM 2 DME 2 channel 2 S2 etc.

Table 14

Designation	Values	Meaning
Time for Soft ON	0 sec., 1 min., 2 min. 3 min., 4 min., 5 min. 6 min., 7 min., 8 min. 9 min., 10 min., 12 min. 15 min., 20 min., 30 min. 40 min., 50 min., 60 min.	Duration of the dimming-up phase (t1) for <u>Soft switching</u> (see Appendix). 0 sec. = switch ON immediately Notice: For further information, please see appendix: Re-triggering and premature switch-off
Dimming value after Soft ON	10 %, 20 %, 30 %, 40 % 50 %, 60 %, 70 %, 80 % 90 %, 100 %	End value at the end of the Soft ON phase Note: Here again the parameterized minimum brightness needs to be taken into account.
Time between Soft ON and Soft OFF	Until “Soft OFF” telegram 1 sec., 2 sec. 3 sec., 4 sec., 5 sec. 6 sec., 7 sec., 8 sec. 9 sec., 10 sec., 15 sec. 20 sec., 30 sec., 40 sec. 50 sec., 1 min., 2 min. 3 min., 4 min., 5 min. 6 min., 7 min., 8 min. 9 min., 10 min., 12 min. 15 min., 20 min., 30 min. 40 min., 50 min., 60 min.	No time restriction; Soft OFF phase is initiated by a telegram Delay (t2) to the start of the Soft OFF phase.
Time for Soft OFF	0 sec., 1 min., 2 min. 3 min., 4 min., 5 min. 6 min., 7 min., 8 min. 9 min., 10 min., 12 min. 15 min., 20 min., 30 min. 40 min., 50 min., 60 min.	Duration of the Soft OFF phase (t3). 0 sec. = switch OFF immediately Notice: For further information, please see appendix: Re-triggering and premature switch-off .

Continued:

Designation	Values	Meaning
Forced operation function	<p>No forced operation function</p> <p>Forced operation through dimming value (0 = inactive)</p> <p>Activate forced operation with 1 Activate forced operation with 0</p>	<p>Forced operation object not present</p> <p>Forced operation is triggered by one-byte telegram with dimming value (see Forced operation object)</p> <p>Activation via 1-bit object 1 = active / 0 = inactive 0 = active / 1 = inactive</p>
Behaviour at start of forced operation	<p>Minimum brightness</p> <p>100 % Off 10 %, 20 %, 30 % 40 %, 50 %, 60 % 70 %, 80 %, 90 %</p>	<p>Response to the receipt of a forced operation telegram</p> <p>Here again the parameterized minimum brightness needs to be taken into account.</p>
Behaviour at end of forced operation	<p>Value before forced operation</p> <p>Minimum brightness 100 % Off 10 %, 20 %, 30 % 40 %, 50 %, 60 % 70 %, 80 %, 90 %</p>	<p>Response to cancellation of forced operation</p> <p>Here again the parameterized minimum brightness needs to be taken into account.</p>
Diagnosis and feedback	<p>None</p> <p>Feedback object, status, general error</p> <p>Load failure, feedback objects, status, general error</p> <p>Excess temperature, feedback objects, status, general error</p> <p>Short circuit, feedback objects, status, general error</p> <p>R,C/L load, feedback objects, status, general error</p> <p>Bus/manual, feedback objects, status, general error</p>	<p>Function of the feedback objects + specific feedback via <u>object 8</u></p> <p>Do not send any diagnosis or feedback telegrams. Objects 5 .. 9 are hidden.</p> <p>Object 5: Dimming value feedback Object 6: ON/OFF status feedback Object 7: General error telegram Object 8: Not used Object 9: Status</p> <p>as above, plus Object 8: Load failure error telegram</p> <p>as above, plus Object 8: Excess temp. error telegram</p> <p>as above, plus Object 8: Short circuit error telegram</p> <p>as above, plus Object 8: Load type feedback</p> <p>as above, plus Object 8: Bus/manual operation feedback</p>

Continued:

Designation	Values	Meaning
Sending diagnosis and feedback	<p>Only in the event of change</p> <p>Cyclically and in the event of change</p>	<p>Only to be sent when something has changed</p> <p>To be sent at regular intervals and again after a change</p>

4 APPENDIX

4.1 Applications for the "Soft switching" function

4.1.1 General

The "Soft switching" function is a cycle comprising the following stages: switching on, dimming up, maintaining target brightness, dimming down and switching off.

4.1.2 Simulation of a daily routine

In conjunction with a timer, it is possible to simulate an entire daily routine with sunrise and sunset. To do this, the parameter "Time between Soft ON and Soft OFF" needs to be set to "Until Soft OFF telegram" (see object 3, Soft switching).

The timer sends object 3 a Soft ON telegram (=1) in the morning and a Soft OFF telegram (=0) in the evening.

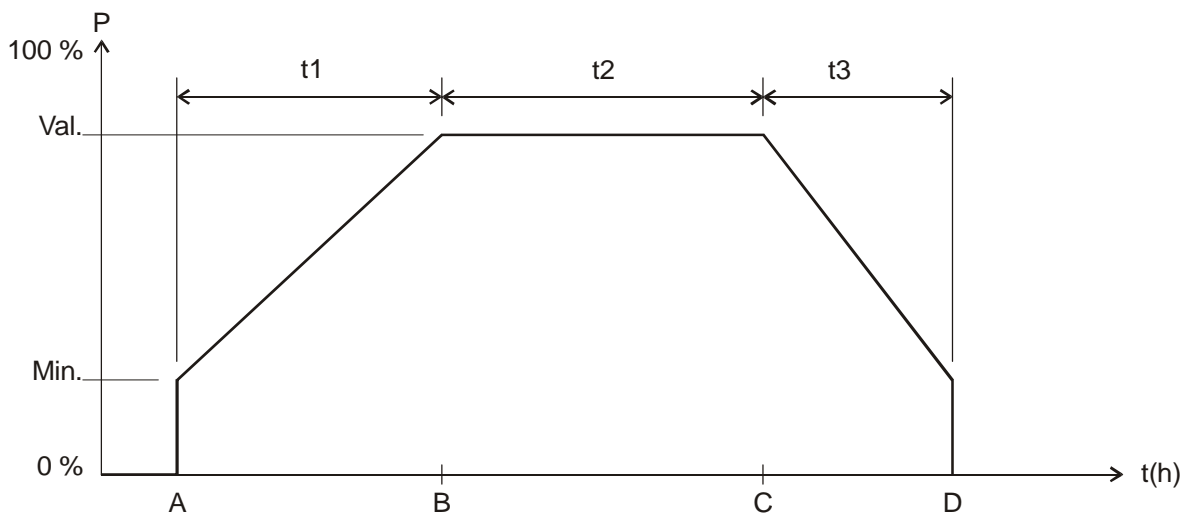

Sequence:

A	Soft ON sent by the timer: The brightness is adjusted to the parameterized <i>minimum brightness</i>
t1	The brightness is gradually increased within the parameterized time for <i>Soft On</i> .
B	Parameterized value after <i>Soft ON</i> is reached.
t2	Time programmed in the timer between <i>Soft ON</i> (1) and <i>Soft OFF</i> telegram (0)
C	<i>Soft OFF</i> telegram has been received: start of the <i>Soft OFF</i> phase
t3	The brightness is gradually reduced within the parameterized time for <i>Soft OFF</i> .
D	t3 has elapsed, the parameterized <i>minimum brightness</i> has been reached and the system dims to 0%.

Key

Min.	Parameterized <i>minimum brightness</i>
Val.	Target brightness, i.e. parameterized <i>Dimming value after Soft ON</i>
t(h)	Time

4.1.3 Soft ON for staircase lighting

The following function is recommended for staircase lighting:

When the light switch is operated: full brightness.

After expiry of the desired time: the lighting is slowly dimmed down and then switched off.

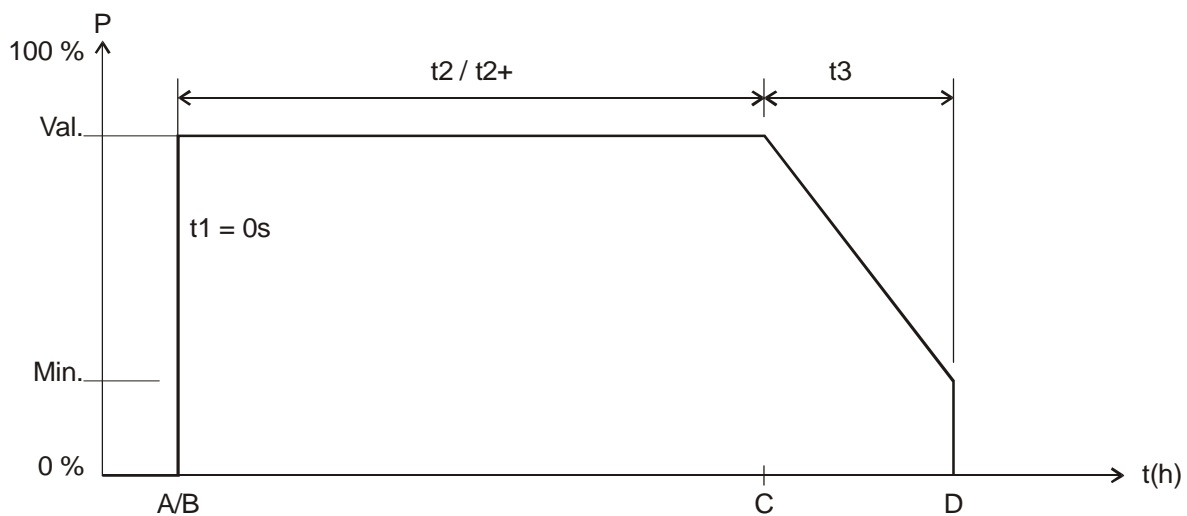

A	Switch/pushbutton sends a <i>Soft ON</i> telegram.
t1	The <i>Soft On</i> time is equal to 0, i.e. the function “Dim up slowly“ is deactivated.
B	The brightness is immediately adjusted to the parameterized value after <i>Soft ON</i> .
t2	Parameterized time between <i>Soft ON</i> and <i>Soft OFF</i> * elapses.
t2+	It is possible for t2 to be extended with another <i>Soft ON</i> telegram.
C	t2 or t2+ has elapsed, or a <i>Soft OFF</i> telegram was received: start of the <i>Soft OFF</i> phase
t3	The brightness is gradually reduced within the parameterized time for <i>Soft OFF</i> .
D	t3 has elapsed, the parameterized <i>minimum brightness</i> has been reached and the system dims to 0%.

* *Soft OFF* via parameterized time or via *Soft OFF* telegram.

The lighting can be switched off with a *Soft OFF* telegram or re-triggered with a *Soft ON* telegram.

4.1.4 Entrance lighting

A motion sensor activates the dimmer via the soft switching object. If a movement is reported then the lighting is dimmed up within 5 seconds. This delay gives the eyes enough time to adjust to the light without being dazzled. After the parameterized time has elapsed or a Soft OFF telegram is received via the switch or via the motion sensor (cyclic), the lighting is gradually dimmed down within a minute and then switched off.

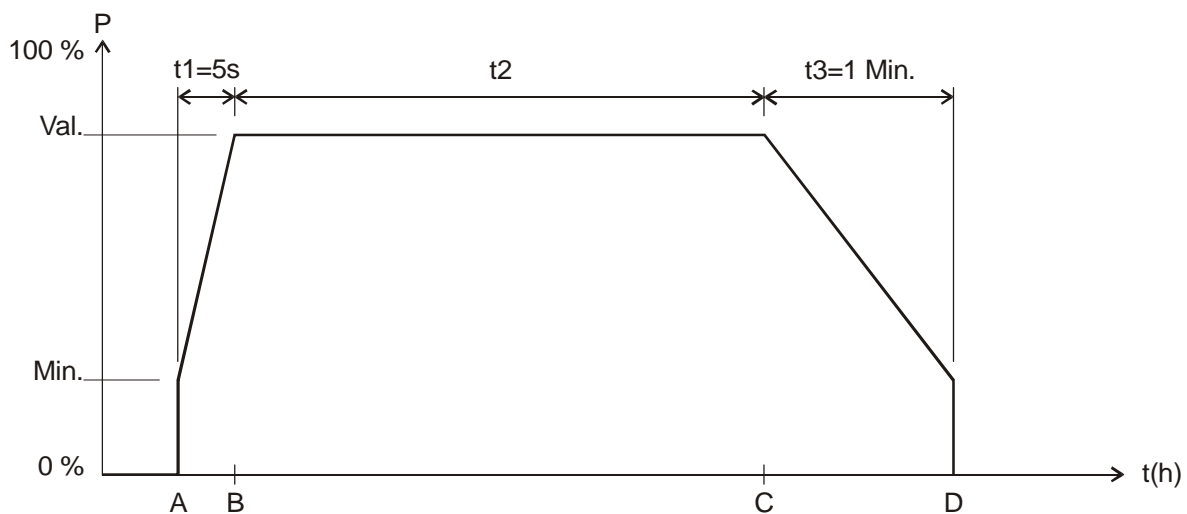

Sequence:

A	Soft ON is sent by the motion sensor: The brightness is adjusted to the parameterized <i>minimum brightness</i>
t1	The brightness is gradually increased within the parameterized time for <i>Soft On</i> (5s).
B	Parameterized value after <i>Soft ON</i> is reached.
t2	Time between <i>Soft ON (1)</i> and <i>Soft OFF</i>
C	Soft OFF telegram was received or parameterized time has elapsed: start of the <i>Soft OFF</i> phase
t3	The brightness is gradually reduced within the parameterized time for <i>Soft OFF</i> .
D	t3 has elapsed, the parameterized <i>minimum brightness</i> has been reached and the system dims to 0%.

4.1.5 Re-triggering and premature switch-off

It is also possible to influence a running soft dimming sequence. Following reactions can be initiated, depending on the current situation:

Table 15

Telegram	Reaction
Soft-ON during t1	none
Soft-ON during t2	t2 is re-started
Soft-ON during t3	A new Soft-ON procedure is started (See below).
Soft-OFF during t1	The Soft-ON procedure is interrupted and the Soft-OFF procedure is started immediately (See below).
Soft-OFF during t2	Soft-OFF procedure is started immediately
Soft-OFF during t3	none

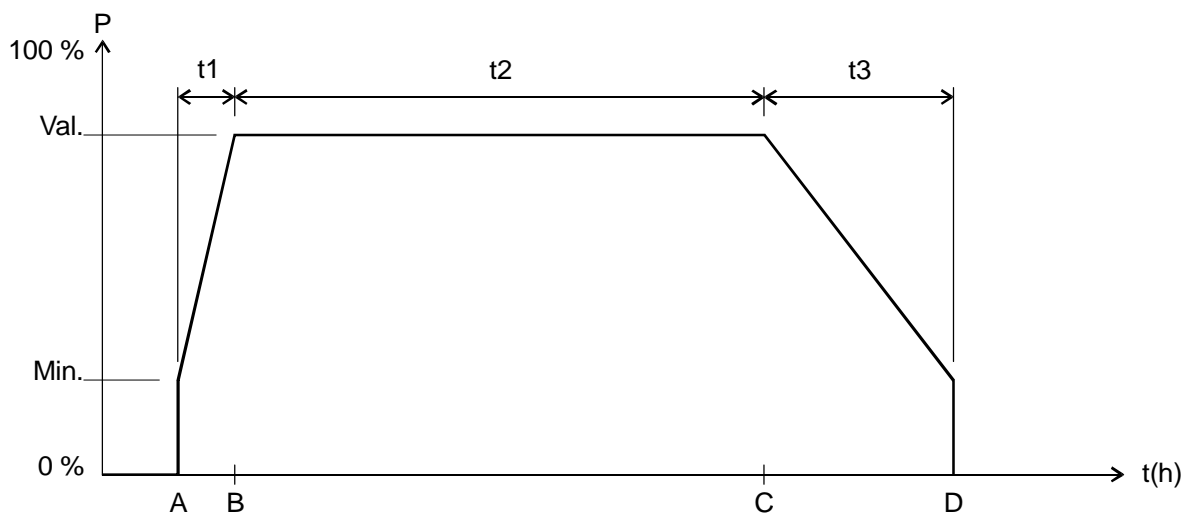

Soft-OFF telegram during Soft-ON procedure.

The duration of the Soft-OFF procedure ($t3'$) always corresponds to the parameterized time, independently of the current dimming value.

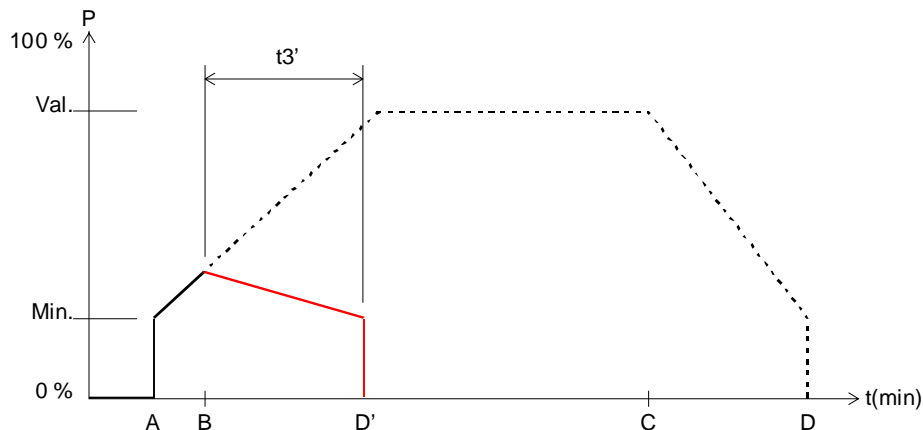

Example 1: Soft-OFF in the beginning of a Soft-ON procedure.

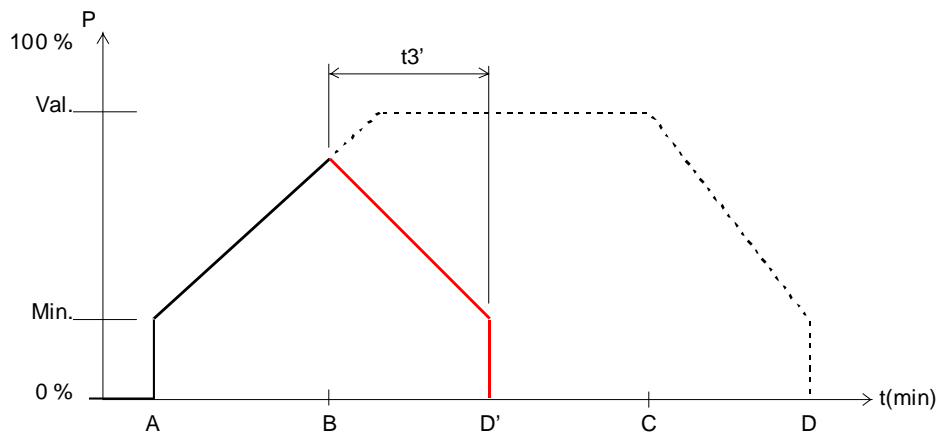

Example 1: Soft-OFF close to the end of a Soft-ON procedure.

Sequence:

A	Soft-ON procedure was started
B	Soft-OFF telegram was received: Soft-ON procedure is interrupted and Soft-OFF procedure is started.
$t3'$	Duration of the soft-OFF procedure = parameterized time for soft-OFF.
D'	End of the Soft-OFF procedure.

Soft-ON telegram during Soft-OFF procedure.

The duration of the Soft-ON procedure ($t1'$) always corresponds to the parameterized time, independently of the current dimming value.

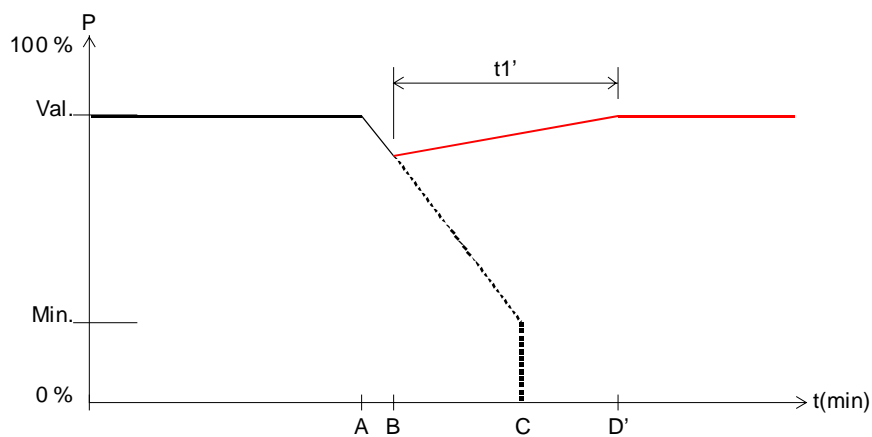

Example 3: Soft-ON in the beginning of a Soft-OFF procedure.

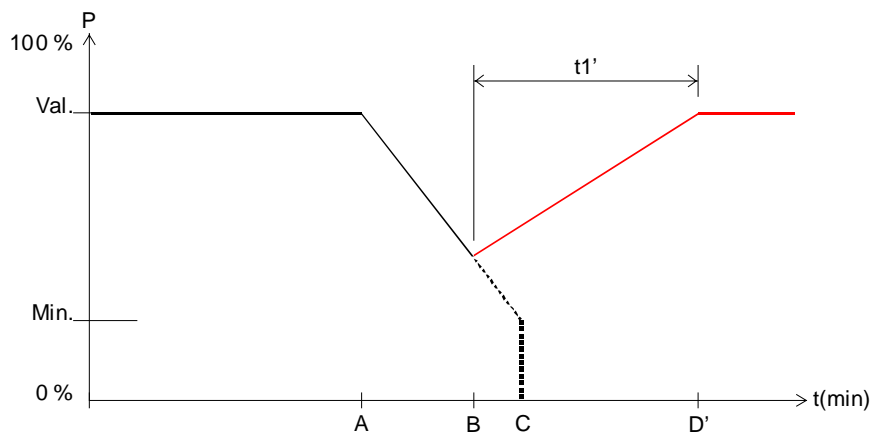

Example 3: Soft-ON close to the end of a Soft-OFF procedure.

Progression:

A	Soft-OFF procedure was started
B	Soft-ON telegram was received: Soft-OFF procedure is interrupted and Soft-ON procedure begins.
$t1'$	Duration of the soft-ON procedure = parameterized time for soft-ON.
D'	End of Soft-ON procedure

4.2 4-bit telegrams (brighter/darker)

4.2.1 4-bit EIS 2 telegram format for relative dimming:

Table 16

Bit 3		Bits 0 .. 2	
Direction		Dimming range divided into increments	
		Code	Increments
Dim up:	1	000	Stop
Dim down:	0	001	1
		010	2
		011	4
		100	8
		101	16
		110	32
		111	64*

*typical application

Examples: 1111 = increase brightness by 64 increments
 0111 = decrease brightness by 64 increments
 1101 = increase brightness by 16 increments

4.2.2 Parameter: "Switching on/off with a 4-bit telegram"

In general, the setting "Yes" is required.

The setting "No" is available for use with special customer requests, e.g. in conference rooms.

The situation is described below.

A whole group of dimmer channels is operated from a switch (4-bit).

A certain lighting situation has been adjusted by a scene or through other means – e.g. channel 1 OFF, channel 2 40%, channel 3 50%. The requirement is to now dim up and increase the brightness of the entire scene, but the channels which are switched off should remain off.

The parameter "Switching on/off with a 4-bit telegram" disables the standard switch on/switch off function of the 4-bit telegram.

Table 17

Parameter: "Switching on/off with a 4-bit telegram"	4-bit telegram	Dimmer output status	Response
Yes	Brighter/darker	Switched on (1%...100%)	Channel is dimmed in the normal fashion (to 0%* or 100% if applicable).
	Brighter	Off	Channel is switched on and dimmed
No	Brighter/darker	Off	Dimmer stays switched off
	Brighter/darker	Switched on (1%...100%)	Channel is dimmed within a range between min. and 100% .

* With the 4-bit telegram "Darker", the channel is switched off if the switch/button is kept depressed for longer than approximately 2s when the minimum brightness is reached.

4.3 Conversion of percentages to hexadecimal and decimal values

Table 18

Percentage value	0%	10%	20%	30%	40%	50%	60%	70%	80%	90%	100%
Hexadecimal	00	1A	33	4D	66	80	99	B3	CC	E6	FF
Decimal	00	26	51	77	102	128	153	179	204	230	255

All values from 00 to FF hex. (0 to 255 dec.) are valid.

4.4 Application of the forced operation function

Example: Lighting with brightness control during the daytime and minimum lighting during the night.

The brightness controller permanently measures the brightness of the room and actuates the dimmer as required to keep the brightness constant.

A dimming value of 20% is parameterized for forced operation.

In the evening at the close of work, the timer activates forced operation mode, as a result of which the brightness is dimmed down to 20%.

During the night, the lighting is switched on for a certain period of time by the night watchmen via the central permanent ON function.

In the morning at the start of work, the timer cancels the forced operation mode again and the dimmer is actuated via the brightness control.

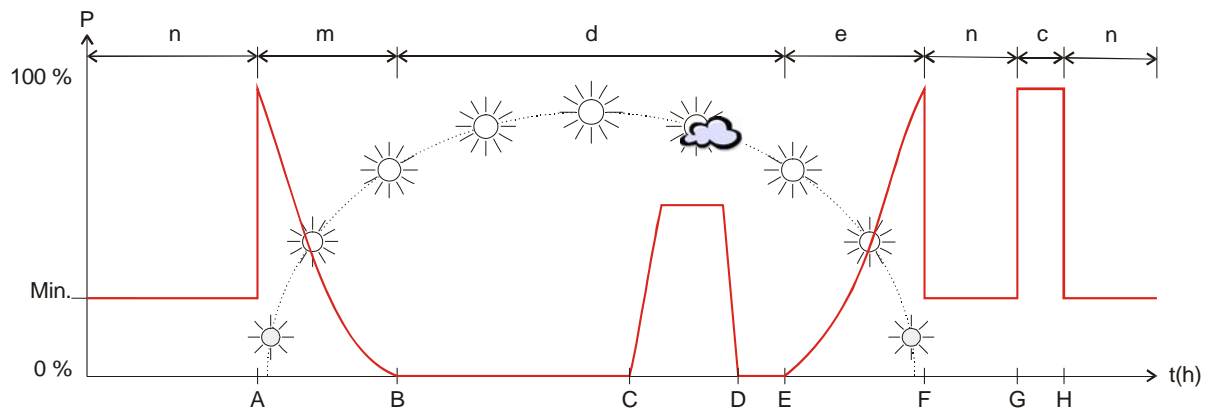

Table 19

A	Forced operation is cancelled by the timer. As the daylight is not yet bright enough the brightness control actuates the dimmer.
B	The daylight is now bright enough to illuminate the room and the dimmer is switched off.
C	Heavy cloud cover, the dimmer compensates for the lack of bright daylight.
D	Clear sunshine, the dimmer is turned back down.
E	Late afternoon, the dimmer gradually replaces the receding daylight.
F	Forced operation is activated by the timer. The dimmer reduces the light to 20%.
G	Central permanent ON = 1
H	Central permanent ON = 0
n	During the night time, the parameterized value for forced operation applies.
c	For the walk around of the nightwatchmen: the lighting is switched on via central permanent ON.
m	Morning: Daylight increases and the brightness control slowly reduces the dimming value.
e	Evening: Daylight decreases and the brightness control slowly increases the dimming value.
d	During the daytime, the dimmer is actuated by the brightness control according to the brightness of the sunlight.

4.5 Saving light scenes in a push button

Scenes are usually saved in the DMG 2, using **object 63** (scenes).

But if you want to save the scenes external, e.g. in a scene compatible switch sensor (e.g. Busch Triton), proceed as following:

The DMG2 has one dimming object (dimming value) and one feedback object (feedback in %) per channel.

Two group addresses are thus used, referred to below as “Gr.Adr.1” and “Gr.Adr.2”.

4.5.1 Assignment of group addresses and setting for the object flags

	Object	Connect with	Set sending	Flags*				
				K	L	S	Ü	A
SWITCH SENSOR	Brightness value telegrams	Gr.Adr.1	yes	✓	-	✓	✓	x
		Gr.Adr.2	No					
DIMMER	Dimming value	Gr.Adr.1	x	✓	-	✓	x	x
	Feedback in %	Gr.Adr.1	No	✓	✓	-	x	x
		Gr.Adr.2	yes					

* Object flags: Communication, read, write, transmit, update
 x = don't care

Feedback functions must not be configured for cyclical sending.

4.5.2 Functional description

Saving a scene:

The switch sensor sends a read request to Gr.Adr.1 which is only replied to by the object “Feedback in %” and with Gr.Adr.2.

Gr.Adr.2 is not processed by the object "dimming value".

In contrast, the sensor receives the value and saves it for the appropriate scene.

Calling a scene:

The sensor sends the value saved for the scene with the % object using the sending address Gr.Adr.1.

The value of the object “dimming value” is processed to set the output brightness.

Once the dimmer has set the requested value, it sends feedback with the object “Feedback in %” depending on the configuration.

4.6 Dimmer actuator priority sequence

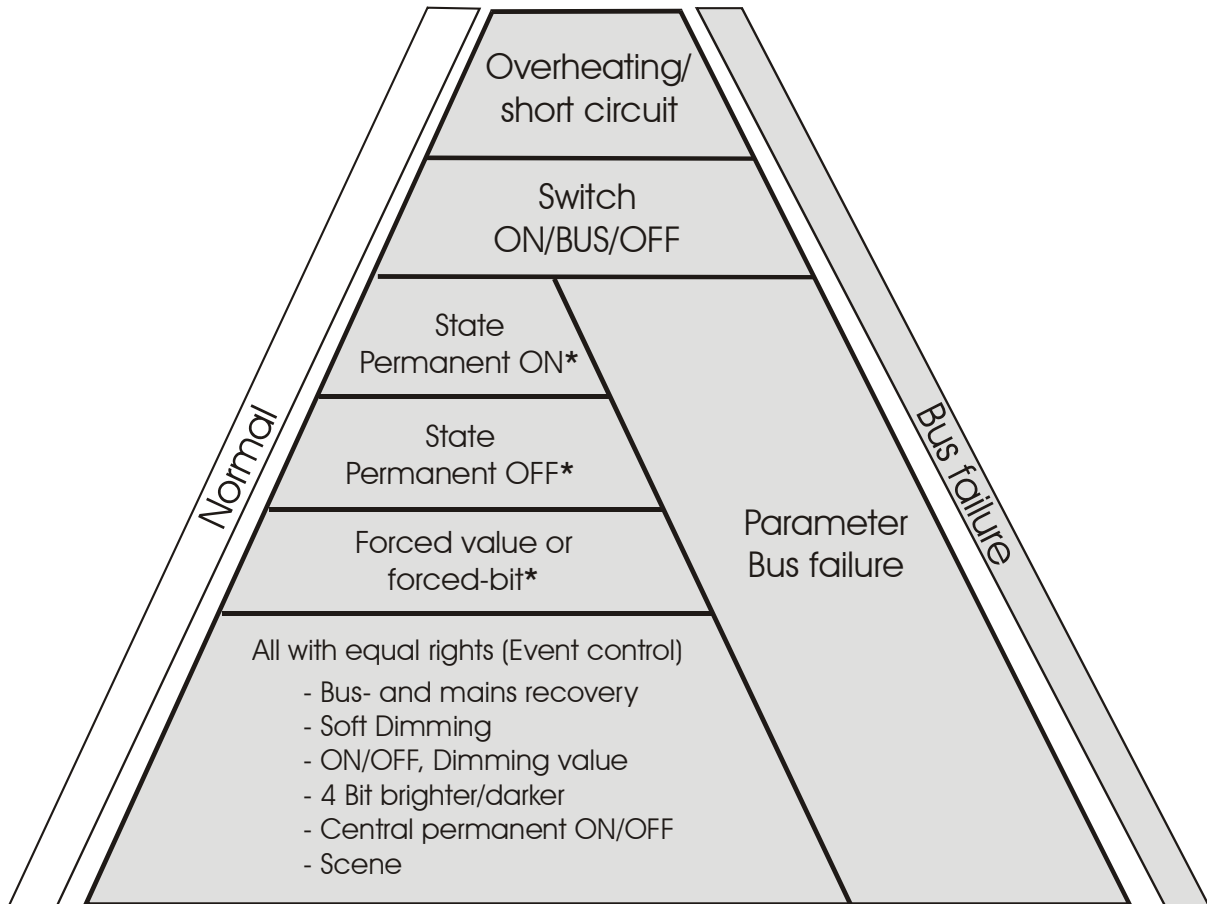

* if parameterized

4.7 Function diagram for standard applications

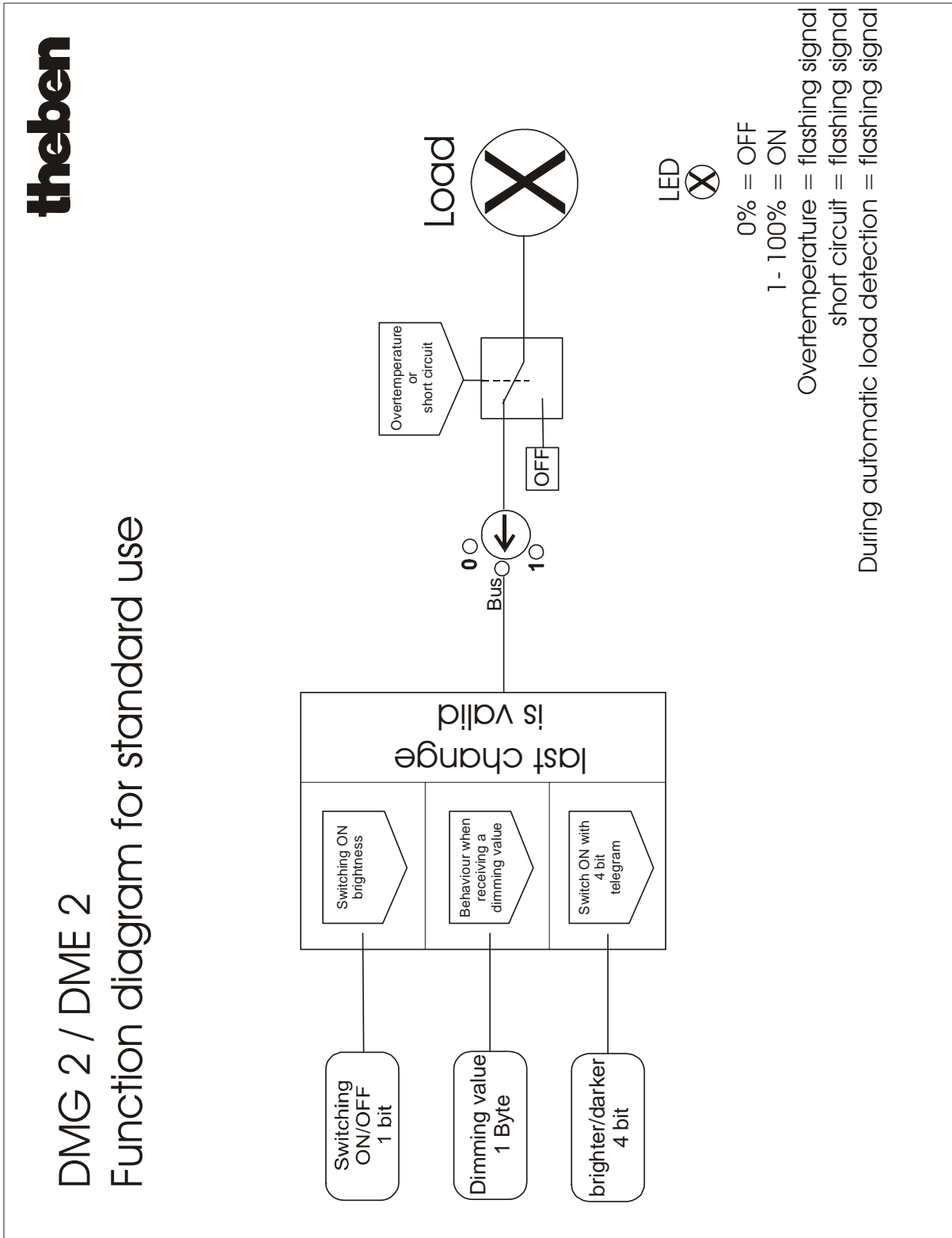

4.8 General function diagram

